

BENSON
CABINET HEATER
(OIL FIRED)

INSTALLATION COMMISSIONING
SERVICING
USER INSTRUCTIONS

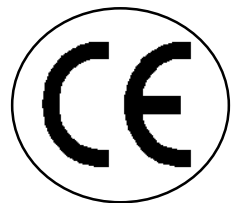

October 2007
Issue 8

THIS MANUAL SHOULD BE LEFT WITH THE END USER .
TO ENSURE SERVICE AND MAINTENANCE INFORMATION IS AVAILABLE ON SITE

~ CONTENTS ~

SECTION 1

	PAGE NO
1.0 Compliance Notices	4
1.1 Certificates of Conformity	5
1.2 General Product Information	5
1.3 General Requirements	5
1.4 Delivery & Pre-installation Checks	6
1.5 Warranty	6
2.0 Location & Positioning	8
2.1 Fuel Supply - General	8
2.2 Fuel	9
2.3 Fuel Storage Tank	9
2.4 Single Pipe System - Gravity Feed	9
2.5 Two Pipe System	12
2.6 Pressurised Ring Main System	12
2.7 Pipe work and Fittings	12
2.8 Electrical Supply	12
2.9 Air Supply	13
2.10 Minimum Space Requirements	13
2.11 Air Distribution System	13
2.12 Flue System	14
3.0 Installation	15
3.1 Packaging & Siting	15
3.2 Flooring	15
3.3 Minimum Clearances	15
3.4 Assembly	19
3.5 Flue Installation	19
3.6 Oil Installation and Connection	19
3.7 Electrical Installation & Connection	20
3.8 Air Distribution Installation	20
3.9 Warm Air Registers	20
3.10 Heater Control Installation	20
4.0 Commissioning	21
4.1 Pre-Test	21
4.2 Ignition	22
4.3 Air Delivery System	23
4.4 Hand Over	24
5.0 Servicing	26
5.1 Planned Servicing	26
5.2 Servicing Procedure - Major Component Parts	26
5.3 Servicing – Re-commissioning	28
6.0 Fault Diagnosis By Flow Charts	29
7.0 Wiring Diagrams by Model and Burner Type	32
8.0 Technical Data	38
9.0 Reference Documents - Standards, Codes of Practice	41
9.1 Parts Listing	42

SECTION 2 BASIC USER INSTRUCTIONS

10.0 Introduction

- 10.1 Commissioning/hand over
- 10.2 Servicing
- 10.3 Start up procedure
- 10.4 Stop procedure
- 10.5 Shutdown procedure
- 10.6 Ventilation only
- 10.7 Lockout situations
- 10.8 Contact Information

ILLUSTRATIONS

	Page No's
Exploded view	7
Fuel Systems and Storage	10-11
Flue Systems	16-19
Fan and Motor Configurations	25
Fault Diagnosis Flow Charts	29-31
Wiring Diagrams	32-37

Any reference made to Laws, Standards, Directives , Codes of Practice or other recommendations governing the application and installation of heating appliances and which may be referred to in Brochures, Specifications, Quotations, and Installation, Operation and Maintenance manuals is done so for information and guidance purposes only and should only be considered valid at the time of the publication. Benson Heating cannot be held responsible from any matters arising from the revision to or introduction of new Laws, Standards, Directives, Codes of Practice or other recommendations.

1.0 Compliance notices

The following information is relevant to the Oil fired Cabinet Heater range manufactured by Benson Heating. These heaters are manufactured within a strictly controlled quality environment within the parameters of ISO 9001.

The Benson Cabinet range has been tested and assessed for compliance with the following European Directives.

Machinery Directive (89/392/EEC)
Low Voltage Directive (73/23/EEC & 93/68/EEC)
Electromagnetic Compatibility Directive (89/336/EEC & 91/31/EEC)
Product Liability Directive (65/374/EEC)

The manufacturer has taken reasonable and practical steps to ensure that Benson Cabinet Heaters are safe and without risk when properly used. These heaters should therefore only be used in the manner and purpose for which they were intended, and in accordance with the recommendations detailed herewith.

The heaters have been designed, manufactured, assembled, inspected, and tested, with safety and quality in mind, there are certain basic precautions which the installer and user should be aware of, and they are strongly advised to read the appropriate sections of the information pack accompanying the heater, prior to installation or use.

Benson Heating supports all new products being supplied to their customers with a comprehensive information pack; this clearly defines mandatory instructions for the safe installation, use, and maintenance, of the appliance (s).

Where proprietary items are incorporated into Benson Heating products, detailed information and instructions are also provided as part of the information pack.

It is the responsibility of the installer, owner, user, or hirer, of such products supplied by Benson Heating, to ensure that they are

familiar with the appropriate information/ manuals, supplied by the manufacturer, and that they are suitably aware of the purpose of the manuals and the safety instructions. In addition, operators must be suitably trained in the use of the appliance so as to ensure its continued safe and efficient use.

Benson Heating has a commitment to continuous improvement, and therefore reserves the right to amend or change the specification of the Cabinet Heater range subject to compliance with the appropriate European, National, and Local regulations.

Contained within the text of the manual, the words '**Caution**' and '**Warning**' are used to highlight certain points.

Caution is used when failure to follow or implement the instruction (s) can lead to premature failure or damage to the heater or its component parts.

Warning is used when failure to heed or implement the instruction (s) can lead to not only component damage, but also to a hazardous situation being created where there is a risk of personal injury.

NOTE
THE WARRANTY REGISTRATION CARD SUPPLIED WITH THE HEATER MUST BE COMPLETED AND RETURNED IN THE PRE-PAID ENVELOPE TO BENSON HEATING ON COMPLETION OF COMMISSIONING

Warranty claims made without this condition being fulfilled will not be processed

The Benson Range of Oil fired Cabinet Heaters conform to the following harmonized standards;

BS EN 292 - Part 1 : 1991
Safety of Machinery - Basic Concepts, General Principles for Design Basic terminology, methodology

BS EN 292 - Part 2 : 1991
Safety of Machinery - Basic Concepts, General Principles for Design Technical Principles and Specifications

BS EN 60204 - Part 1 : 1993
Safety of Machinery - Electrical Equipment
for Machines Specification for General
Requirements

BS EN 60335 - Part 1 : 1988
Safety of Household and Similar Electrical
Appliances
General Requirements

BS EN 55014 - 1993
Limits and methods of measurement of radio
disturbance characteristics of electrical
motor-operated and thermal appliances for
household and similar purposes, electrical
tools and similar electric apparatus

BS EN 50165 - 1997
Electrical Equipment of non-electric heating
appliances for household and similar
purposes, safety requirements

1.1 Certificates of conformity

Certificates are available from the Quality Control Department at Benson Heating

1.2 General product information

The Benson models have an output range from approximately 29.16 kW to 380 kW, and are available in a configuration that will allow for down flow, horizontal, or floor mounting.

The units can suit either ducted applications, or be used as free blowing units, but each heater must be connected to its own individual open flue

Each heater is fitted with a forced draught burner which has been test fired and pre-set prior to despatch. The safety functions of the burner are by way of a fully sequential control box fitted to the burner.

Note

Neither asbestos nor soft soldered joints are used in the construction or manufacture of the Benson range of Cabinet Heaters. The materials selected for use can withstand the mechanical, chemical, and thermal stresses which they will be subject to during foreseen normal use when installed in accordance with the manufacturers recommendations.

1.3 General requirements

Caution

Ensure that the fuel supply is in accordance with the manufacturer's recommendations and is as stated on the appliance data plate.

Installation, commissioning, and servicing must only be carried out by appropriately qualified and competent persons.

Warning

Unauthorised modifications to the appliance, or departure from the manufacturers guidance on intended use, or, installation contrary to the manufacturers recommendations may constitute a hazard.

Note

To ignore the warning and caution notices, and to ignore the advice from the manufacturer on installation, commissioning, servicing, or use, will jeopardise any applicable warranty, moreover, such a situation could also compromise the safe and efficient running of the appliance itself, and thereby constitute a hazard.

The installation of the appliance must meet all the relevant European, national, and local criteria.
(See sections 3 and 9).

Prior to installation the following points should be considered;

- a) The position of the heater for the optimum efficient distribution and circulation of warm air
- b) The position of the heater relative to the route of the flue
- c) The position of the heater relative to the supply of fuel
- d) The position of the heater relative to the electrical services, and if appropriate, any additional controls.
- e) The position of the heater relative to the supply of fresh air

f) The position of the heater relative to service and maintenance requirements

Caution

The heater must not be installed within an area where the conditions are unsuitable, e. g. where the atmosphere is highly corrosive, has a high degree of salinity, or where high wind velocities may affect burner operation. Suitable protection should be provided for the appliance when it is located in a position where it may be susceptible to external mechanical damage from; for example, fork lift trucks, overhead cranes etc.

1.4 Delivery and pre-installation checks

The heater is supplied wrapped in heavy duty protective polythene. On receipt of the heater, the following checks should be carried out;

- a) The model is as per order
- b) That it is undamaged
- c) That it is suitable for the fuel supply
- d) That it is suitable for the electrical supply

If any of these points are not satisfied then contact should be made with the Sales Office at Benson Heating as soon as possible by Telephoning 01547-528534. In the case of claims for damage, this must be signed for as damaged and be reported in writing within 24 hours of delivery, in order to comply with insurance criteria

1.5 Warranty

The heater is supplied with a 2 year warranty made up as follows; first year covering parts and labour, and second year covering parts only. In addition to this there is also a 10 year time related warranty on the combustion chamber/heat exchanger. The warranty commences from the date of despatch from the manufacturer, and is subject to the terms detailed within the Benson Heating conditions of business.

Note (i)

The warranty may be invalidated if -

- a) The warranty registration/commissioning card has not been completed and returned to Benson Heating
- b) The installation is not in accordance with the general requirements of this manual
- c) The flue arrangement and air supply for the heater are not in accordance with the manufacturers recommendations, codes of practice, or similar standards
- d) Air flow through the heater is not in accordance with the manufacturers technical specifications
- e) Internal wiring on the heater has been tampered with or unauthorised service / repairs undertaken
- f) The main electrical supply input to the heater has been interrupted during the heating mode
- g) The heater has been subject to and affected by the ingress of water in any form
- h) The heater is not operated at the rating(s) laid down in the manufacturers technical specifications
- i) The heater has not been operated or used within the normal scope of its intended application
- j) The manufacturer's recommended minimum service requirements have not been complied with

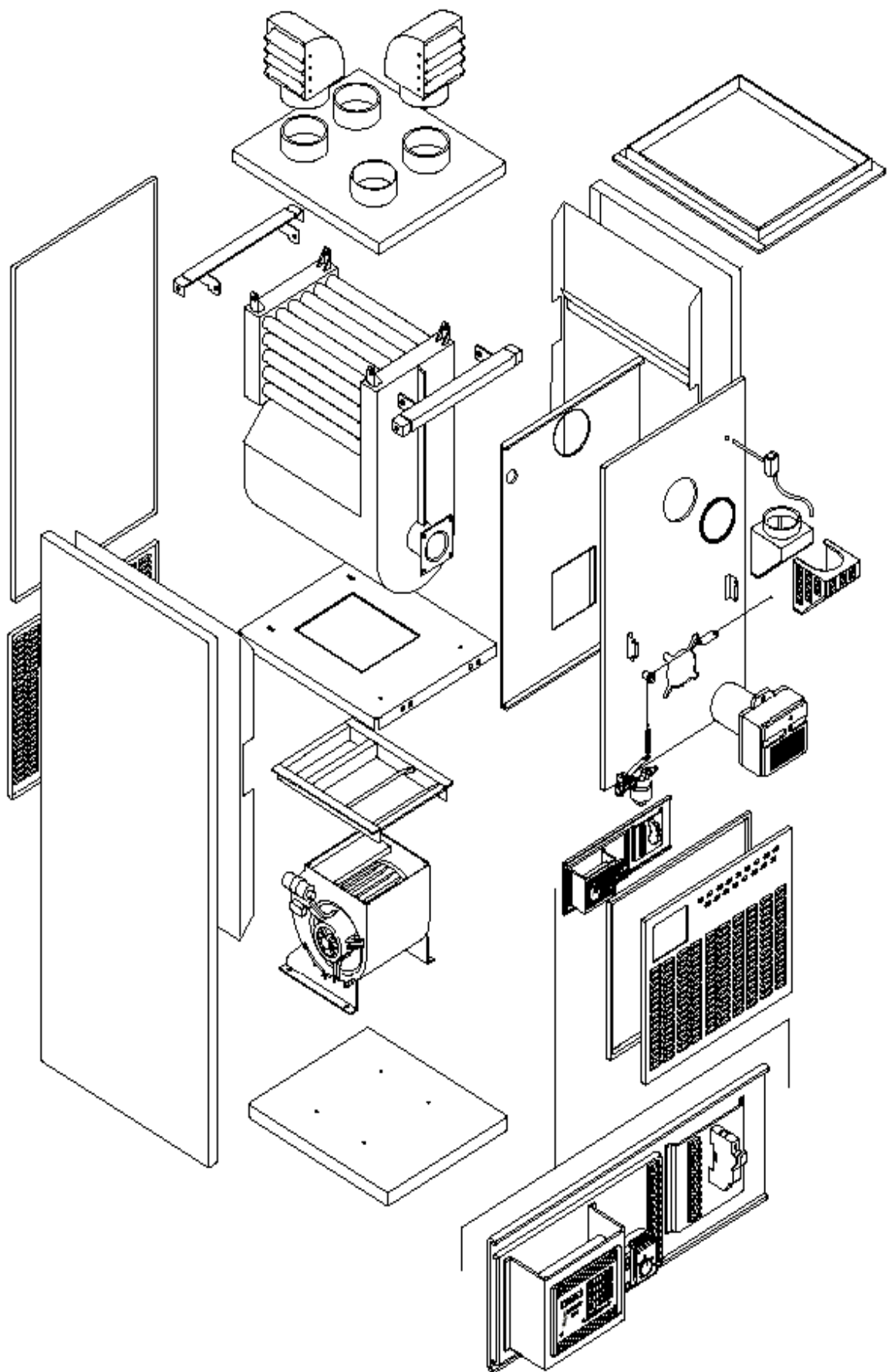

Note (ii)

All warranty claims must contain the following information to enable processing to take place;

- (1) Heater model
- (2) Heater serial number
- (3) Order reference/date of order, together with full installation details (name and address)
- (4) Details or symptoms of fault
- (5) Installers name and address.

Faulty parts must be returned to the Knighton Spares Department, the address of which is provided in **Section 2** of this manual. Any such parts will undergo inspection to verify the claim. Replacement parts supplied prior to this may be charged, and a credit supplied upon subsequent validation of the warranty claim. Consumable items are specifically not included within the scope of the warranty.

Note (iii)

Notification is required immediately a fault is suspected.

The manufacturer will not accept responsibility for any additional damage that has been caused, expense incurred, or consequential loss resulting from any failure of the heater(s).

2.0 Location/positioning

Warning

All of the basic criteria must be satisfied prior to commencing installation and commissioning, additionally, the Cabinet Heater must be positioned and installed so as to comply with all the relevant standards and guide lines (**see section 9.0**), as well as meeting National and Local Fire Regulations and Insurance criteria, especially if it is proposed that the heater is to be installed within a special risk area (e.g. proximity to where petrol engined vehicles are stored or parked, where cellulose spraying takes place, where woodworking machinery is operated, etc.).

Indirect fired heaters must not be located in hazardous areas, however, it is permissible for the heater to supply air to such areas.

The heater must not be installed within an

environment where there is a high concentration of chlorides, fluorides, salts, or other aggressive or volatile chemicals/compounds. Nor should the heater be positioned where high winds or draughts could adversely affect the burner.

The location chosen for the heater must allow for the fitting of an effective flue system.

The location must also allow for adequate clearance for the air supply, return air circulation, oil supply, electrical supply, whilst also providing good and safe working access.

The heater must be installed on a flat and level surface made from non-combustible material, which is sufficiently robust to withstand the weight of the heater and any ancillary equipment. Any combustible material adjacent to the heater or flue system must be so placed or shielded so that its surface temperature does not exceed 65°C.

In areas where it is proposed that more than one heater is to be installed, a general scheme of circulation should be drawn up and maintained, thereby offering the best heat distribution.

All Benson Heaters are fitted with a pressure relief facility, this is incorporated into the design of the flue gas exit duct. Care should therefore be taken in siting service connections and controls well away from the pressure relief vent.

Warning

Under no circumstances must the pressure relief be restricted, blocked, or have the free exit of exhaust gas impaired or re-directed.

2.1 Fuel supply - general

The Benson range of oil fired cabinet heaters are all manufactured and pre-set for use with 35 second gas oil delivered to the burner via a suitable piped system from the oil storage tank.

Galvanised or plastic pipe work and fittings must not be used. (see BS 5410 Part 1 1997)

The constraints of the application will, to a large extent, determine whether it is preferable to use a single pipe gravity feed system, or whether the two pipe pumped system is more appropriate.

Where more than one appliance is to share a common supply it will be necessary to use a pressurised ring main system.

All pipe work must be constructed and installed so that it does not permit the ingress of air.

The construction, size, and position of the oil storage tank must take account of the current regulations, as well as suiting the requirements of the installation.

Please refer to figures 2 - 8 for additional information.

Caution

On pumped systems always check that the pump is correctly set up prior to running, and always ensure that valves are open allowing a free flow of oil through the system.

2.2 Fuel

In order to promote trouble free operating it is necessary that the oil within the storage tank and oil line does not fall below the cold filter plugging point (cfpp), in this country and with class D fuel (also referred to as gas oil). The critical temperature is -4°C for this summer grade.

The cfpp critical temperature for the winter grade is -12°C. If summer grade fuel is stored for winter use in areas prone to severe frosts and low temperatures it will be necessary to insulate or even heat the supply tank and pipe work.

Note

The fuel supplier should be contacted prior to installation so that any requirements concerning delivery, transport, storage and use can be addressed before work commences.

Warning

The inlet pump pressure must not exceed a maximum of 0.4 bar, this is because beyond this point gas is liberated from the oil.

2.3 Storage tank

An externally painted steel storage tank to BS 799 part 5 1987 or a medium density

polyethylene oil tank OFTEC certified to OFS T-100 may be used. Local, national, European and fire regulations must also be complied with.

They must include the following.

A fuel level gauge (not made from glass) a vent pipe with a diameter greater than that of the filler and featuring a weatherproof termination. A sludge valve.

An outlet valve situated at the opposite end of the tank to the sludge valve.

A filler pipe connection situated at the opposite end to the outlet valve.

The size of the storage tank must take account of the estimated consumption and any quantity price breaks offered by the oil supplier.

It is preferable to install the tank outside, however, if this is not practicable and the tank has to be installed indoors advice must be sought about its siting, especially so far as fire regulations are concerned.

If a separate fire resistant chamber cannot be provided for indoor installations, a catchment pit with a capacity ten percent greater than that of the storage tank must be provided

Storage tanks can if necessary be sited on a roof, but this is subject to special regulations as well as local authority approval and compliance with fire regulations, reference to **BS 5410 part 2 1978 & part 1 1997** is strongly suggested.

It is advisable to leave the tank unpainted on the inside, but to paint the outside with a proprietary grade of anti-corrosive paint. A galvanised or open topped tank is strictly not allowed.

All oil storage tanks require a bund

The Control of Pollution Regulation (Oil Storage) 2001 should be consulted prior to installation

2.4 Single pipe system (gravity feed)

For installations where the oil tank is 200mm or more above the level of the fuel pump the principle of gravity feed may be used.

The draw off point for the supply to the burner must not be positioned any lower than 100mm above the bottom of the tank.

Where a return valve is fitted this must be tamper proof to prevent inadvertent operation.

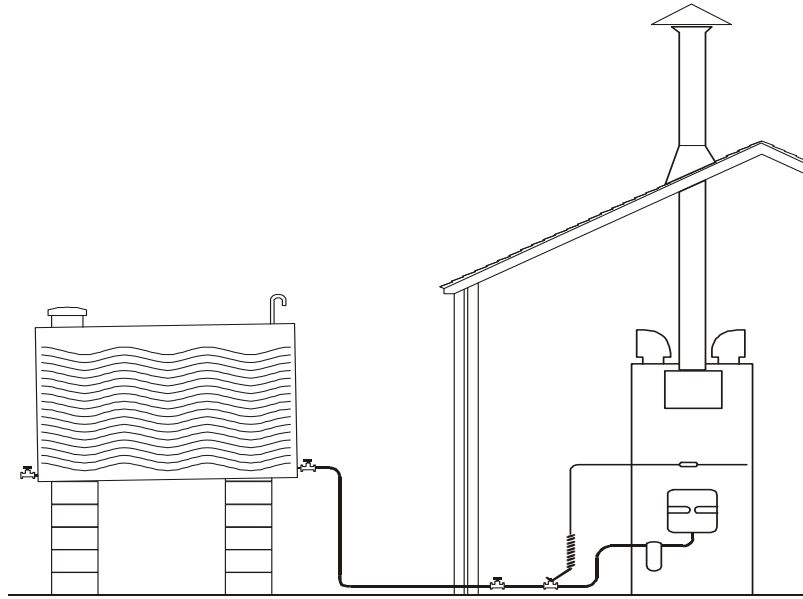

Typical arrangement of oil storage tank and single pipe system

- 1 GATE VALVE
- 2 IN-LINE FILTER
- 3 PUMP
- 4 RELIEF VALVE
- 5 PRESSURE GAUGE
- 6 PRESSURE REDUCING VALVE
- 7 RETURN TO TANK

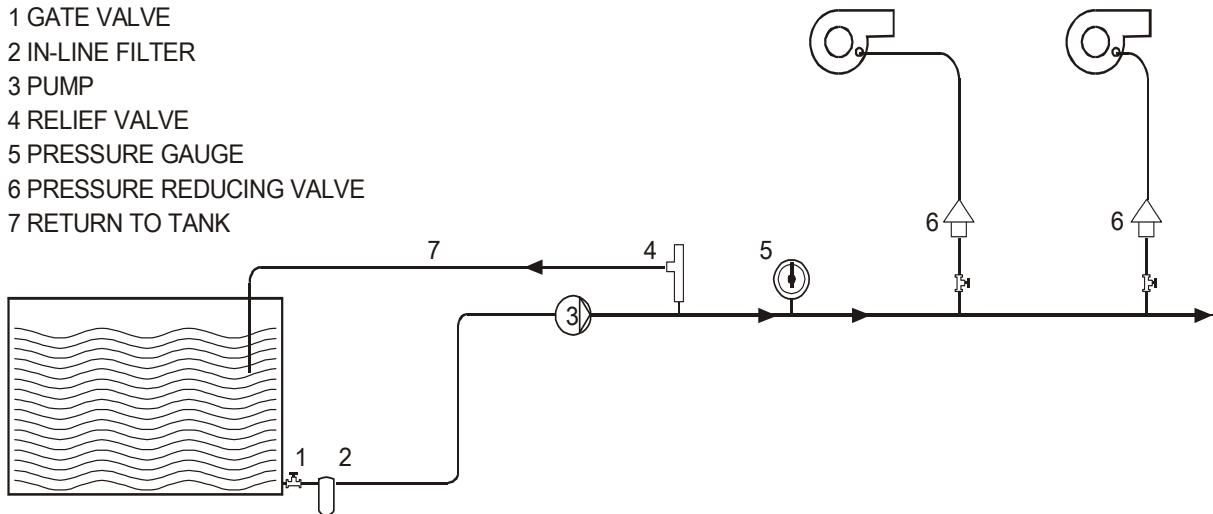

Pressurised oil feed system

WARNING:

Before starting the burner make sure that the return pipeline is not clogged;
Any obstruction would cause the pump seals to break

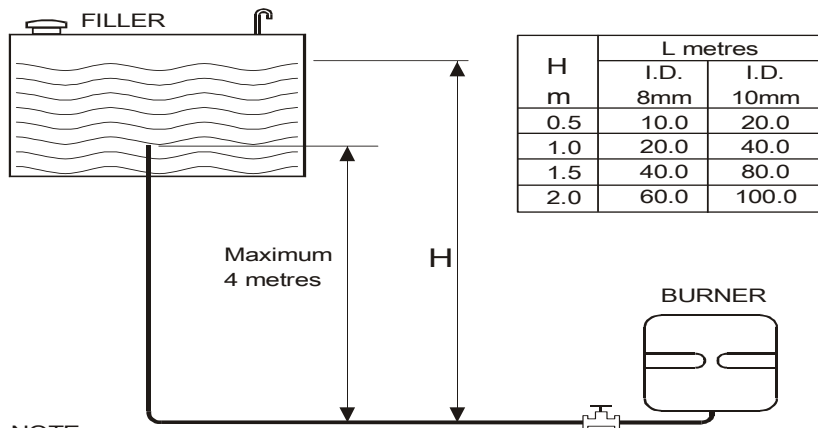

NOTE:

All burners are despatched suitable for gravity feed installations

Burner oil pump details for heater models 100-600 oil lines

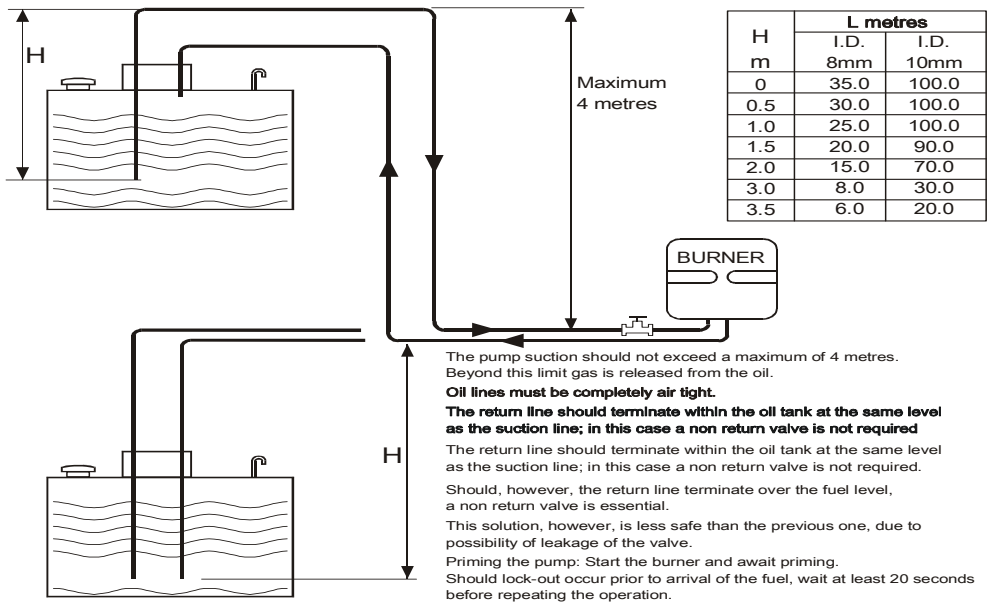

Burner oil pump details for heater models 100-600 oil lines

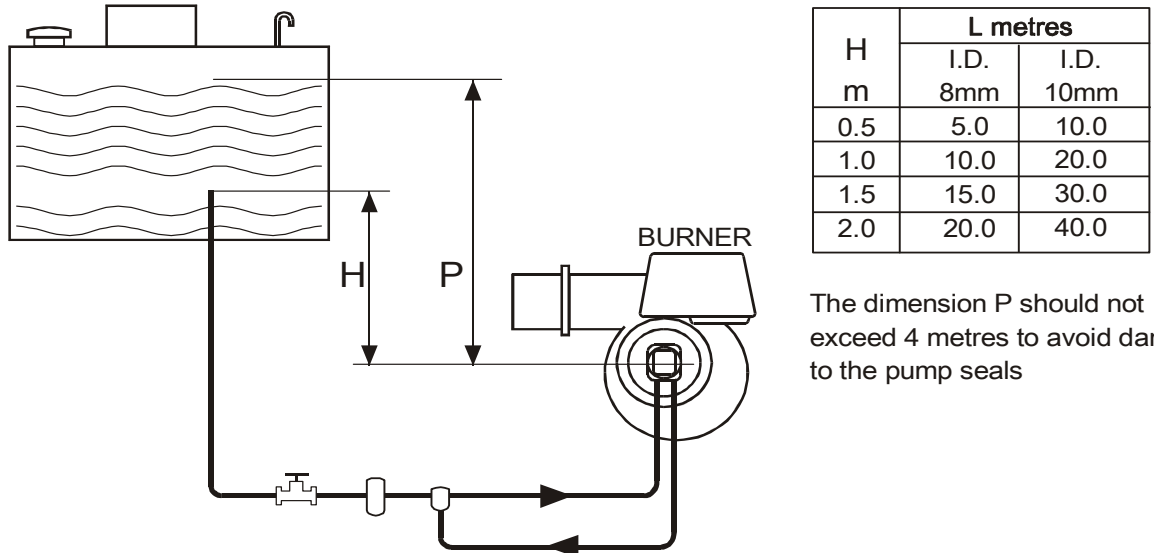

Burner oil pump details 700-1300 gravity feed from bottom of tank

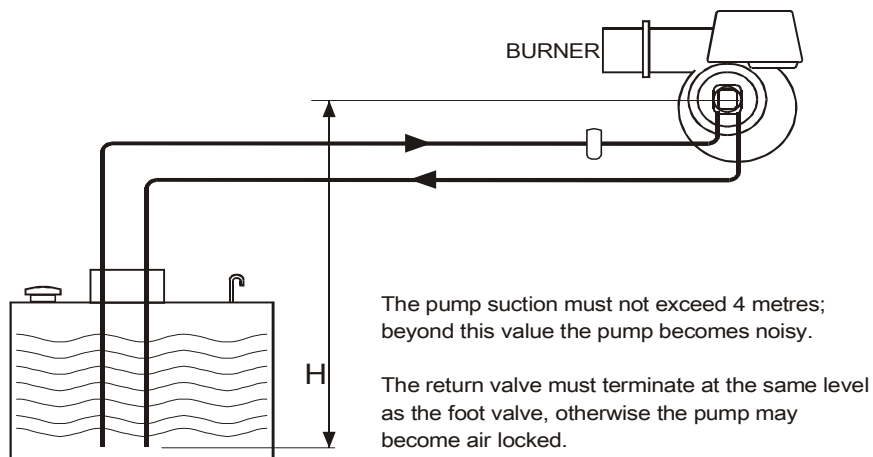

Burner oil pump details 700-1300 suction feed

Caution

If the valve is closed when the pump is running the oil pressure can be increased sufficiently so as to cause damage to the seals within the pump.

The return oil should preferably be discharged through an elbow onto a tank plate situated within the tank, this should be positioned so as not to introduce air or air bubbles into the draw off pipe.

2.5 Two pipe system

This is used where the oil storage tank is lower than the pump.

Access for the fuel feed to the burner should be via a suitable tapping made in the top of the tank, and the fuel feed pipe should extend to not less than 100mm above the bottom of the tank.

A non return valve with a metal to metal seat should be fitted, especially if the return pipe work is terminated at a level above the draw off tube. The non- return valve must be removable for service and maintenance purposes, and the return pipe from the pump must therefore be extended down into the tank to the same level as the suction pipe.

The presence of a tamper proof isolating valve fitted within the return pipe is only required if there is a risk that oil will siphon out of the tank if the return pipe is disconnected at the pump during maintenance or servicing and if the non return valve has been omitted.

2.6 Pressurised ring main system

This system is used to supply a number of units from a common storage tank.

A booster pump is used to provide the pressure to push the oil around the ring main and back to the tank.

Pressure reducing valves should be fitted on the delivery pipe to each heater to ensure that the delivery pressure at the heater is less than 6 psi.

Caution

The internal by-pass plug must be removed from the burner pump when used in a pressurised ring main application.

2.7 Pipe work and fittings

Caution

Galvanised or plastic pipe work and fittings must not be used. (see BS 5410 Part 1 1997)

All joints must be sealed properly, if necessary using PTFE tape or other approved sealing media.

The pipe work must be effectively sealed so as to prevent the ingress of air.

It is advisable to check all pipe work prior to installation to ensure that there is no loose debris or scale present.

Black iron pipes can be hammered to assist in the removal of these contaminants.

Note

The oil feed to each heater must be fitted with a fire check valve and isolating valve. The fire check valve must be operated by way of a fusible link positioned so that it is above the burner.

2.8 Electrical supply

Wiring external to the cabinet heater must be installed in accordance with any local, national, and European regulations, as well as meeting the appropriate requirements of IEE regulations.

The means of connection to the main electrical supply must allow for complete electrical isolation of the heater, furthermore, in the case of a unit wired for a three phase supply, the supply should only be used to serve the heater itself and no other plant or equipment. The position of the isolation switch must be such that it is adjacent to the heater and easily accessible at all times. In addition, the isolator itself must have a contact separation of not less than 3mm.(as per BS5991 clause 20.2). The Control fuse ratings are detailed on the appliance data plate.

Warning

Ensure that the electric and oil supplies are turned off before any electrical work is carried out on the heater.

Ensure that wiring cannot make contact with any surfaces liable to be subject to high temperatures or where the insulation of the wiring could be impaired as a result of such contact.

All cabinet heaters must be earthed.

Caution

The main electrical supply must not be switched off or disconnected as a method for stopping the heater, the exception to this is in an emergency, or during servicing, when the heat exchanger has been allowed to cool sufficiently to prevent any damage from occurring. Claims for damage will not be considered if they have resulted from incorrect wiring or the incorrect use of the heater.

2.9 Air Supply

Consideration must be given to the provision of air for the purposes of combustion and ventilation of the heated space, plant room or enclosure where heaters are to be installed
Benson Heating recommend the following

Note

It is strongly recommended that BS 6230 : 2005 is referred to for further information concerning ventilation requirements Where mechanical ventilation is used it is a requirement that the inlet is of the mechanical type, and the outlet is either mechanical or natural.

2.9.1 Heaters installed within the heated space

Where heaters are installed within the space to be heated (I.e. not a plant room or enclosure)

Combustion air or heater related ventilation air

Will not be required if

The design air change rate of the heated space is 0.5 air changes per hour or greater The design air change rate may be satisfied by natural infiltration or by mechanical ventilation

Combustion and General ventilation

will be required if

The design air change rate of the heated space is less than 0.5 air changes per hour

Where the heated space has an air change rate of less than 0.5 air changes per hour then it will be necessary to provide **either** natural ventilation openings to the heated space (section 2.3.1.1. refers) **or** the mechanical ventilation of the heated space (section 2.3.1.2. refers)

2.9.1.1 Natural Ventilation Openings to the Heated Space

If the heated space design air change rate is less than 0.5 air changes per hour then provision for low level natural ventilation openings will only be necessary

The minimum free area of the low level natural ventilation opening shall be

- 2cm² for each kW of rated heat input

The low level natural ventilation opening should be situated on an external wall and be within 1000 mm of floor level

The table below provides specific data for each heater model as -

Model	Minimum Free Area of ventilation opening	
	High Level	Low Level
	cm ²	cm ²
100	None	64
125	None	79
150	None	97
200	None	127
250	None	160
300	None	193
400	None	257
500	None	291
600	None	386
700	None	460
800	None	515
1000	None	623
1200	None	769
1300	None	847

2.9.1.2 Mechanical Ventilation to the Heated Space

In the event that the heated space has a design air change of less than 0.5 air changes per hour and that installer prefers to mechanically ventilate the heated space rather than provide ventilation openings then -

- The heated space needs to be mechanically ventilated so that the design air change is 0.5 air changes or greater.
- It is a requirement that the mechanical ventilation shall be of the 'input' type with either natural or mechanical extraction.
- Systems of mechanical extraction with a natural inlet shall not be used
- It is necessary to provide an automatic means to safely inhibit heater(s) operation should mechanical air supply fail for any reason

2.9.2. Heaters Installed within a Plant Room or Enclosure

A plant room means a room housing the heater plant and probably other items of building service plant and would generally have generous space for maintenance

An enclosure is where the heater is installed within a compartment or confined area where space is limited

Where heaters are installed within a plant room or enclosure then provision for both combustion air and air for general ventilation will be required by means of high **and** low level ventilation openings (sections 2.9.2.1 refers to plant room applications and sections 2.9.2.2 refers to enclosure applications).

Alternatively the plant room or enclosure may be mechanically ventilated (section 2.9.2.3 refers)

2.9.2.1 Natural Ventilation Openings to Plant Rooms

For plant room applications the minimum free area of ventilation opening shall be

- At high level 2 cm² for each kW of rated heat input
- At low level 4 cm² for each kW of rated heat input

The high level ventilation opening should be sited on an external wall and positioned as high as is practical and always within the top 15% of the wall height

The low level natural ventilation opening should be situated on an external wall and be within 1000 mm of floor level

The table below provides specific data for each heater model as -

Model	Minimum Free Area of ventilation opening	
	High Level	Low Level
	cm ²	cm ²
100	64	128
125	79	158
150	97	194
200	127	254
250	160	320
300	193	386
400	257	514
500	291	582
600	386	722
700	460	920
800	515	1030
1000	623	1246
1200	769	1538
1300	847	1694

2.9.2.2 Natural Ventilation Openings to Enclosures

For enclosure applications the minimum free area of ventilation opening shall be

- At high level 5 cm² for each kW of rated heat input
- At low level 10 cm² for each kW of rated heat input

The high level ventilation opening should be sited on an external wall and positioned as high as is practical and always within the top 15% of the wall height

The table below provides specific data for each heater model as -

Model	Minimum Free Area of ventilation opening	
	High Level	Low Level
	cm ²	cm ²
100	159	318
125	198	396
150	244	488
200	317	634
250	400	800
300	483	966
400	643	1286
500	726	1452
600	965	1930
700	1152	2304
800	1287	2574
1000	1558	3116
1200	1922	3844
1300	2118	4236

The low level natural ventilation opening should be situated on an external wall and be within 1000 mm of floor level

2.9.2.3 Mechanical Ventilation to a Plant Room or Enclosure

In the event that the installer prefers to mechanically ventilate the plant room or enclosure rather than provide ventilation openings then -

- The plant room or enclosure needs to be mechanically ventilated at the rate of 4.14 m³/h of fresh air per kW or rated heat input.

The table below provides specific data for each heater model as -

MODEL	Mechanical Ventilation Rate for Plant Room or Enclosure
	M ³ /h
100	139
125	172
150	206
200	274
250	353
300	409
400	567
500	717
600	822
700	987
800	1131
1000	1410
1200	1627
1300	1830

- It is a requirement that the mechanical ventilation shall be of the 'input' type with either natural or mechanical extraction. Where mechanical extraction is selected then the extraction rate should be 5%-10% less than the input rate.
- Systems of mechanical extraction with a natural inlet shall not be used
- It is necessary to provide an automatic means to safely inhibit heater(s) operation should mechanical air supply fail for any reason

2.10 Minimum space requirements

The minimum space requirements for single and multiple heater applications are detailed in section 3.3 later within this manual.

2.11 Air distribution system

All materials used within the construction of the delivery and return air ducts must not represent a fire hazard and should be made from thermally inert materials. The selection of materials must take account of the environment into which the heater and its air delivery system is expected to work, it must also take account of the stresses and loadings placed upon it during its normal working life. Where interjoist spaces are used to route ducting these must be lined with fire resistant insulation material.

In installations where forced recirculation is a feature, a full and unobstructed return air path to the heater(s) must be provided, with return air grilles connected by ducting directly to the return air inlet on the heater.

The limit for recirculation should not be greater than 85% re-circulated air to 15% fresh air.

Where the heater is installed within a compartment or plant room the return air and discharge air arrangement must be such that the air circulation fan does not interfere with the operation of the flue.

The return air intake and warm air outlet should therefore be fully ducted to and from the heater, respectively, within the compartment or plant room.

If the inlet air is ducted to the outside, then the lowest edge of the inlet air duct must be at least 500mm above the outside floor or ground level, it must also be fitted with an access point(s) to allow for cleaning and servicing to occur.

The openings in the structure of the plant room, through which the ductwork passes must be of fire resistant material and constructed to prevent the likelihood of any fire from spreading.

In ducted applications the ductwork must be designed so as to give a static pressure within

the limits stated in section 8 of this manual. It should be noted that if the static pressure is too high, nuisance shut-down will occur when the heater goes out on the overheat limit thermostat, if the static pressure is too low, then damage can be caused to the fan motor.

Warm air outlets on ducted applications must be such that they cannot be closed or become blocked, which again would lead to an increase in static pressure and nuisance shut-down. The outlets must not be sited so that warm air can be discharged onto combustible materials, if necessary, guard rails should be used to ensure that effected areas are kept clear.

Return air intakes must not be located so that potentially harmful or hazardous contaminated air can be drawn into the system.

2.12 Flue system

Warning

It is essential that the products of combustion are flued to the outside of the building. Each heater must have its own separate flue, with a flue diameter of not less than is detailed in section 8 within this manual. The minimum vertical length of flue must not be less than 3m. The flue should rise vertically, and the number of bends should be kept to a minimum. Flue pipe should be supported at intervals not exceeding 1.8mtrs

Flue pipes below a height of 2m should be guarded against the possibility of being accidentally touched when hot by personnel

It is strongly advised that BS 5854; 1980, and BS 5440; parts 1 and 2, are used as consultative documents when considering flue requirements.

Care should be taken to ensure that the flue terminal is not situated in a high-pressure area, the proximity of buildings and other obstacles which will influence this must be taken into account, preferably at the design stage.

See figures 9 - 19.

Provision must be made for the disconnection of the flue for inspection and service requirements, and it is strongly advised that where bends are fitted inspection covers are included.

The materials from which the flue is constructed must be non-combustible, resistant to internal and external corrosion, and be capable of withstanding the stresses and loadings associated with normal use.

When designing the flue system the prevention of the formation and entrapment of condensation must be a key consideration.

Twin wall or insulated systems are recommended, as they tend to inhibit the formation of condensates.

Where condensation is unavoidable traps should be included to encourage the condensates to flow freely to a point from which they may be released, preferably into a gully.

The condensate pipe from the flue to the disposal point must be made from corrosion resistant pipe of not less than the internal diameter of the drain pipe.

If the flue passes through a wall, ceiling, or roof made from combustible material then it has to be sleeved so as to provide a minimum of a 25mm void between the exterior of the flue and the internal wall of the sleeve. The maximum permitted temperature of any adjacent combustible material is 65°C.

The position of the flue and its terminal should be such that it does not impair the combustion process.

It should terminate in an exposed position so as to allow the escape and dissipation of flue gases without risk of their re-entering the property through windows, ventilation ports, etc. The flue should extend to at least 1m above the height of any object within 3.5m of the terminal.

Flue terminals should be fitted on all flues, the terminal must be of the approved type, and have outlet grilles on all sides giving a total free area of at least double that of the flue.

Caution

It is imperative that the flue should be properly sealed where it passes through the roof, this can best be achieved by using the approved method of roof flashing plate and cravat.

Note

It should be noted that claims made under warranty and attributed to the ingress of water may not be considered especially if an approved method of sealing has not been used, or if the design of the flue has not made provision for possible condensation problems.

3.0 Installation

It is strongly advised that the installer reads Section 2 and Section 3 of this manual prior to starting any installation work.

It is a requirement that only qualified and competent personnel may undertake installation, commissioning, and servicing.

Warning

Always ensure that the appropriate personal protective equipment is used.

3.1 Packaging/Siting

The heater will usually be supplied wrapped in heavy gauge polythene, non assembled parts will be supplied separately.

Prior to installation, the assembly of the heater should be completed, it is advisable that this is undertaken in the area where the heater is scheduled to be sited.

Caution

It is strongly advised that when positioning the heater the lifting eyes are used, thereby reducing the risk of inadvertent damage being occasioned to the heater.

3.2 Flooring

The heater must be installed on a level non-combustible surface capable of supporting the weight of the heater and any ancillary equipment.

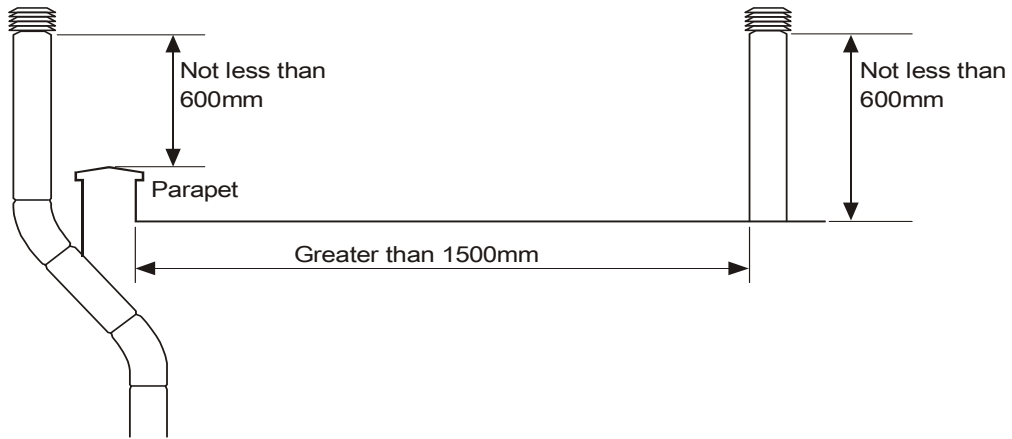

Flat Roof with parapet

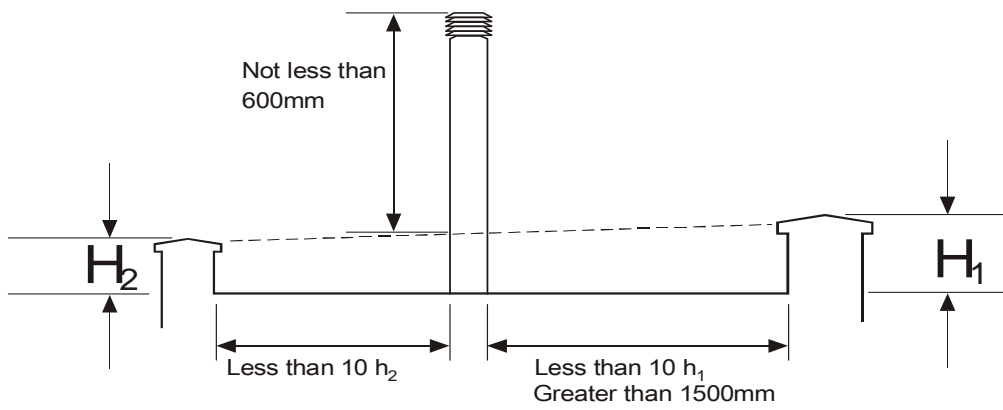

Flat roof envelope method

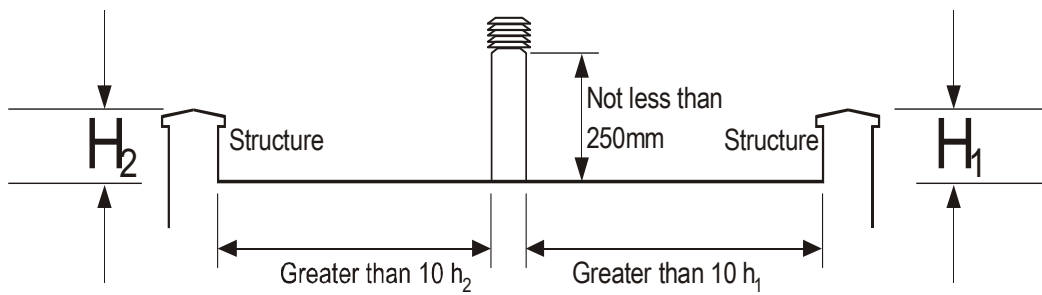

Flat roof where the flue height is more than 10 heights (H) away from all structures

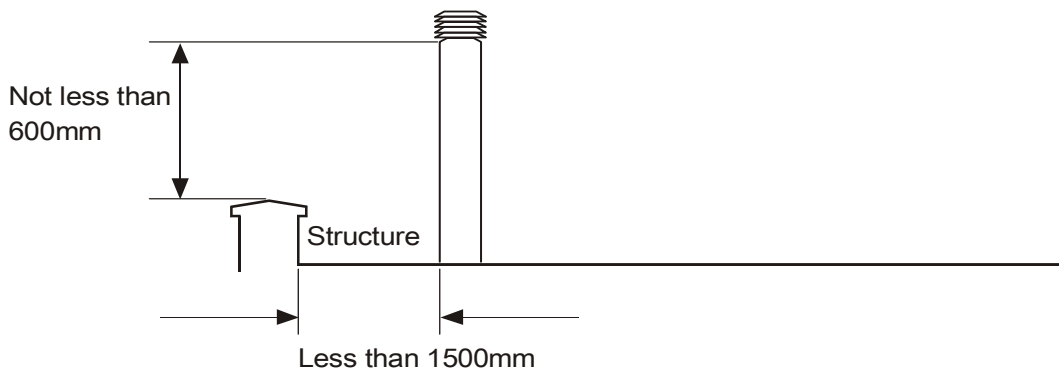

Flat roof with flue close to parapet

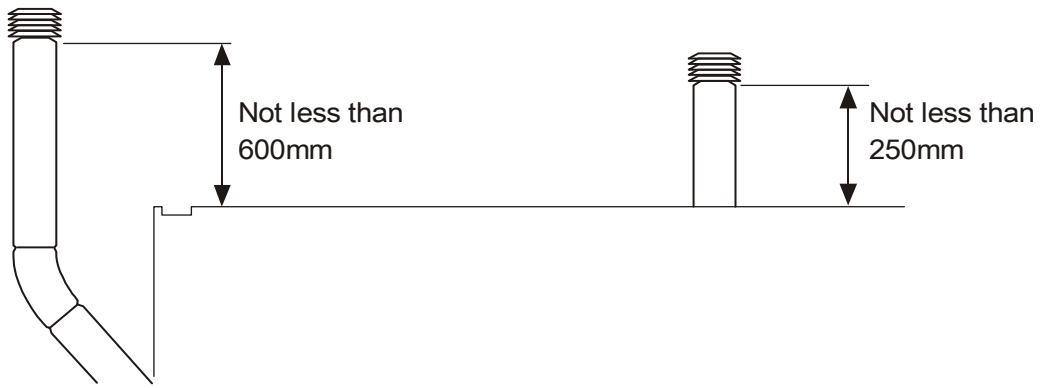

Flat roof with no parapet

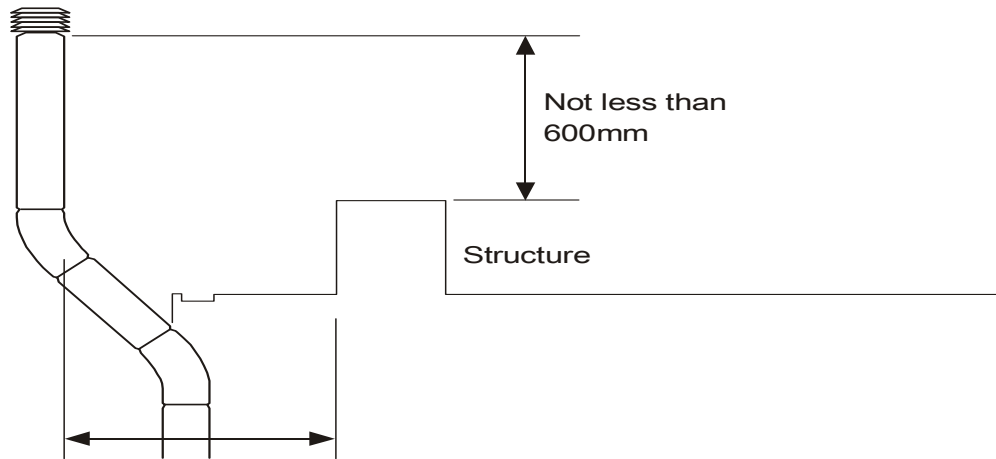

Less than
1500mm

Flat roof with structure close to flue outlet

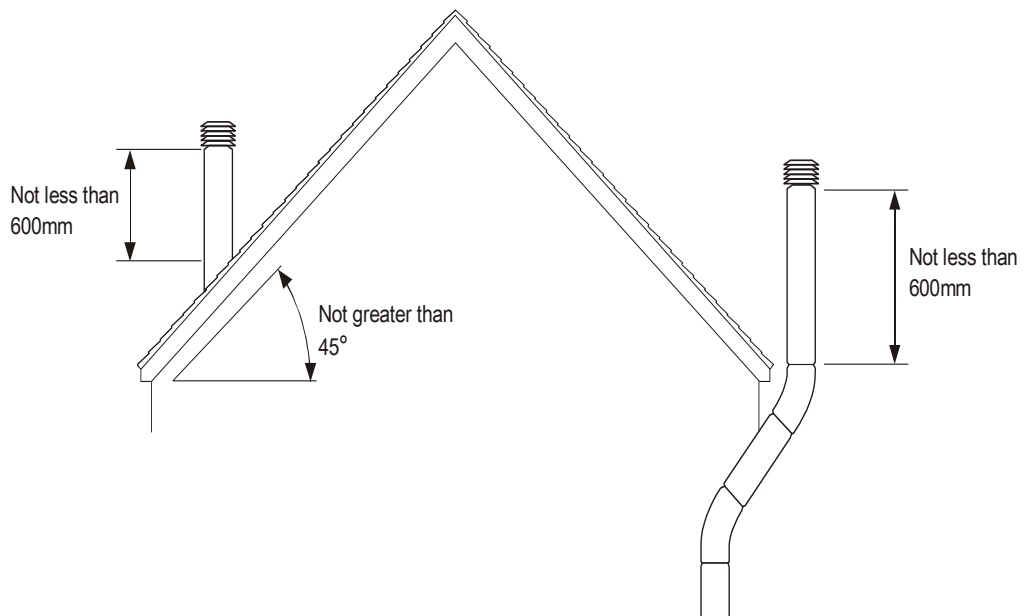

Pitched roof not greater than 45°

3.3 Minimum clearances

The following minimum clearances (in millimeters) are recommended when installing the heater.

Model Size	Front	Rear	Lhs	Rhs
100 - 150	500	700	150	150
200 - 300	500	1,000	150	150
400 - 500	600	1,200	150	150
600	600	1,500	150	150
700	900	1,500	150	150
800 - 1000	900	2,000	400	400
1200 - 1300	900	2,000	500	500

3.4 Assembly

The following sub-assembly parts should be assembled to allow installation to continue.

(a) Vertical Nozzled Models

For free blowing applications it will be necessary to complete the final assembly before continuing with the installation place the nozzle plate onto the top of the heater, align holes, and secure.

Fit the nozzles to the spigots, turning the nozzles to give the required approximate direction for airflow.

Secure nozzles to spigots, when correctly positioned by way of self tapping screws, on completion of commissioning

(b) Horizontal Nozzled Models

Remove packing and secure the 90° Duct Outlet to the heater using the bolts supplied. Secure the nozzle spigot plate to the duct outlet using the bolts and prevailing torque nuts provided. Fit the securing brackets to each of the outlet nozzles, and lift the complete heater assembly and position on the pre-sited purpose built supports. Finish off the assembly by fitting and securing the outlet nozzles to the spigots by way of previously fitted brackets.

3.5 Flue Installation

An integral flue spigot is fitted to all Cabinet Heaters thereby allowing the flue to connect directly to the heater. The design of the flue must ensure that it can be disconnected to allow for cleaning and servicing, furthermore, all of the flue section joint sockets must face upwards, and the seal between the sections achieved through mechanical joints or through the use of approved caulking string and grout. It is strongly advised that BS 5854 and BS 5440 parts 1 and 2 are referred to, see also figs 9 - 19.

Where condensation is likely to be a problem provision should be made preferably at the design stage (see section 2.11).

3.6 Oil Installation/connection

The oil tank must be positioned so that there is a fall of 7.5mm (+/- 2.5mm) for every 30mm away from the outlet and towards the sludge/drain valve, which must be sited at the lowest point in the tank. If the tank is positioned on supports then there must be an adequate protective layer between tank and support to prevent damage or deterioration through corrosion. It is strongly suggested that reference is made to BS 5410 ; part 2 ; 1978.

It is also suggested that the installer is familiar with the detail and requirements contained within sections 2.1 through to section 2.6 of this manual prior to commencing installation.

Warning

Prolonged exposure and contact with Gas Oil can result in the natural oils being removed from the skin, sensitisation can result in dermatitis. Always ensure that the appropriate personal protective equipment is used.

3.7 Electrical Installation/connection

Benson cabinet heaters are available either for 415V 50Hz 3PH or 230V 50Hz 1PH supplies depending upon the model specified.

It is recommended that reference is made to the wiring diagrams contained within section 7 of this manual prior to installation or connection to the supply. The electrical supply must be as specified and suitable for the heater, and must be run within conduit to a point adjacent to the heater, and be terminated to provide an isolation point that will prevent remote or inadvertent activation. Cables, conduit, and fittings that are used to make the connection between the isolator and the heater must conform to the appropriate IEE regulations.

All heaters are supplied fused and pre-wired, all must be earthed.

Final connections for any additional external controls must be completed on site, and must be carried out according to IEE regulations.

Separate user information is provided for the time control unit and the burner, and forms part of the product information pack which accompanies every heater when despatched.

Warning

Always isolate from mains electrical supply before commencing work on the heater.

Always ensure that the appropriate personal protective equipment is used.

3.8 Air Distribution Installation

The materials selected must be of low heat capacity, and it is preferable that all warm air ductwork is thermally insulated.

Where ducting may be subject to deterioration from exposure to moisture or high humidity material selection and insulation are prime considerations. Joints and seams must be airtight and fastened securely and designed to remain so, even when operating at high temperatures.

Adequate support must be designed into the layout of the ductwork to ensure that the integrity of the seams and joints is maintained.

The support must be independent and separate from the heater and the ducting, to allow for free movement during expansion and contraction.

Where ducting passes through walls or partitions sufficient clearance must be left, irrespective of any fire stop requirement, to allow for expansion and contraction. Failure to adhere to these latter two points can result in the generation and transmission of excess noise.

Where ducting is installed in concrete flooring a permanent membrane must be used to isolate the ducting from the corrosive effect of the alkaline salts within the concrete. Care should be taken to ensure that soft insulation material does not become compressed and thereby lose its insulation effectiveness.

3.9 Warm Air Registers

In order that vertical temperature gradients are minimal thereby providing a more even heat distribution, it is preferable to install warm air registers at low wall levels or at floor level, with the size, number, and position commensurate with the requirement of the application.

To minimise noise levels the registers should be set away from corners, additionally, a good seal between the register frame and the wall is important, particularly on high level positions, if unsightly staining through warm air/particulate deposition is to be avoided.

3.10 Heater Control Installation

Unless specified all Cabinet Heaters from 100 to 1300 are manufactured and supplied with a CP2 Control as standard .

The following controls fitted and pre-wired are available as an option

- (a) On/Standby switch
- (b) Ventilation/Heat switch (summer/winter switch)

- (c) Manual/automatic switch
- (d) Thermostat
- (e) Time clock
- (f) Frost stat

All of the above controls are located on a removable panel which when separated from the heater can be re-positioned so as to offer a remote facility.

However, to facilitate this, it is necessary to order and fit an electrical panel cover and front panel blanking plate to the heater in place of the control unit.

A CP4 Controller is available as an option

The controls for Horizontal Cabinets and Reverse Flow are supplied as remote option.

4.0 Commissioning

Note

It is a requirement that only suitably qualified and competent personnel are allowed to undertake the commissioning of the heater.

It is also strongly recommended that prior to commissioning the engineer familiarises himself with; the information contained within the information pack that accompanies the heater, the heater itself, and with the specific requirements of the installation/application.

Warning

All Cabinet Heaters undergo a rigorous test programme prior to being despatched, whilst such a programme does involve pre-commissioning and setting up the heater to operate efficiently and well within its designed operational limits, this does not mean that on site commissioning is less important than might otherwise be the case. The idiosyncrasies of each installation can only ever be allowed for, through the use of thorough on site commissioning carried out by trained and experienced personnel equipped with the correct tools and apparatus.

Note

It is strongly recommended that equipment used for the sampling and analysis of flue gases is accurate to within +/- 0.1% and maintained so that it is regularly calibrated.

4.1 Commissioning - Pretest

Check to ensure electrical safety, and inspect and check the oil installation, testing for leaks.

- (a) Ensure that the electrical supply is turned off.
 - (b) Ensure that the oil supply is turned off.
 - (c) Check that all panels and fasteners are secure and in place.
 - (d) Check that the heater is installed so that it is square and that the support is adequate.
 - (e) Ensure that warm air delivery outlets are open and that ducting is adequately supported.
 - (f) Ensure that if filter assemblies are fitted that they are secure and correctly located.
 - (g) Check that air inlets are clear and that return air paths are adequate.
 - (h) Ensure that the flue is secure, adequately supported, and that the various joints are properly sealed.
 - (i) Check that condensate trap and drain facilities are adequate.
 - (j) Check that there is provision for flue gas sampling and that this sample point can be plugged and sealed after commissioning.
 - (k) Check that fan and limit stat settings have not been disturbed and are as follows

	100/700		800/1000		Range
Fan on	-	60°C	Fan on	-	50°C
Overheat limit	-	100°C	Overheat limit	-	100°C
Fan off	-	30°C	Fan off	-	30°C
- Also check that the white button (automatic) is pulled outward and that the red button (reset) is pushed inwards to the reset position. See fig 15.
- (l) Remove lower panel and check motor and fan drive system for integrity of joints, check pulley alignment, fan rotation, and belt tension (see section 5.2 and figs 23, 24, and 25).

(m) Ensure that the burner is securely attached to the heater.

(n) Test for electrical earth continuity between the heater, oil pipe work, and mains supply.

(o) On Analogue control option Turn on main electrical supply, select the following switch settings

- On/Standby - Standby
- Heat/Ventilation - Ventilation
- Manual/Automatic - Manual

The fan will start enabling fan direction etc to be verified. Reset on/standby switch to off position.

(p) Turn mains electrical supply to off, replace and secure lower louvred panel covering fan and motor assembly.

(q) Set room thermostat and time clock to 'demand' positions.

4.2 Commissioning - Ignition

Warning

Do not proceed with commissioning unless all the criteria detailed within sections 4.0 and 4.1 have been satisfied.

(a) Ensure that the electrical supply is turned off.

(b) Ensure that the oil supply is turned off.

(c) Select the following switch settings on the heater (Analogue Option)

- On/Standby - Standby
- Heat/Ventilation - Heat
- Manual/Automatic - Automatic

(d) Turn on main electrical supply.

(e) Select 'on' position for heater on/standby switch.

(f) Check for the following burner sequence

	Interval	Operand
	1 <5s	Combustion air damper actuated, burner fan motor initiates purge cycle...
	2 <15s	Solenoid valve opens ignition transformer provides spark for burner ignition...
	----- E I T H E R -----	
	3 >15s	Ignition failure caused by oil starvation resulting in burner lock-out/shut-down...
	(g) Set heater on/standby switch to standby position	
	(h) Attach oil manifold (bleed screw and pressure gauge)	
	(i) Open oil supply valves and bleed air from pipe work and adjust burner oil pressure as per detailed in burner manual (section B)	
	(j) Repeat steps 4.1 q, and 4.2 c,e,f.	

----- **O R** -----

	3 >15s	Burner ignition... flame detection...
	4 <20s	Burner ignition cycle complete

Note

It is strongly recommended that the separate manual concerning the operational details of the burner supplied with the heater as part of the information package is studied prior to commissioning.

Time intervals within the ignition sequence will vary slightly from one model to another.

Warning

If burner ignition is not satisfactorily accomplished, commissioning must not proceed until the reason or fault has been identified and rectified, if necessary by reference to the separate burner information or to section 6 of this manual.

Commissioning Ignition cont'd

- (k) Repeat steps 4.2 c,a,
- (l) Repeat steps 4.2 d,e,f, allowing the heater to reach thermal equilibrium.
- (m) Adjust room thermostat to its highest setting, and allow the heater to continue to fire.
- (n) Gradually reduce the temperature setting on the room thermostat until the burner shuts down, (@ < ambient and then gradually increase the temperature setting on the thermostat until heat is called for, (@ > ambient) and the burner automatically re-fires.
- (o) Re-set time clock to a minimum off period, checking that the burner shuts down, and then automatically re-lights once the minimum off period has elapsed (Separate information on the time clock is contained within the information package supplied with the heater).
- (p) Check fan and limit stat by depressing and holding in the fan motor overload re-set button, located on the heater electrical panel. The time between the fan stopping and burner shut down should be noted, once the burner has shut down the overload on the motor should be released. If the time interval between fan stop and burner shut down is greater than 90 seconds further checks should be made. These are as follows
- (i) Check settings on fan and limit stat are correct, for heater supplied ie, fan on 60°C, fan off 30°C, limit 100°C.
- (ii) Check that the position of the unit is correct, ie, equi-distant between heat exchanger body and heat shield panel.
- (iii) Check integrity of unit, ensuring that neither the bi-metallic strip nor its casing is damaged.
- (q) Undertake flue gas analysis using approved and calibrated analysing equipment recording data on the

commissioning card, ie, CO, CO₂, net and gross flue temperatures.

Record burner oil pump pressure, ambient temperature, barometric pressure, and smoke reading (0 - 1 Baccarach scale).

Note (i)

The burner air and oil pressure settings should be only very finely adjusted to achieve a CO₂ reading of 12.5% (+/- 0.5%).

Note (ii)

The gross efficiency must be approximately 80 % sample taken at 1m above the flue spigot point.

Note (iii)

All Cabinet Heaters are test fired and pre-commissioned as part of the manufacturing process, if however, during on site commissioning the data are found to be not in accordance with the manufacturers data, then the following action is recommended.

- * Re-check all readings and calculations.
- * Adjust burner as per manufacturers instructions.

* Consult Benson Heating Technical Department.

(r) Complete commissioning card and provide operating instructions for the user, high-light the fact that the manufacturer recommends that in the interests of safety and efficiency the heater is serviced on a regular basis only by qualified and competent persons. The completed commissioning card must be returned to Benson Heating Service Department immediately after the satisfactory completion of commissioning, failure to do so can invalidate any subsequent warranty claim.

(s) Set all controls to the requirements of the user.

4.3 Commissioning - air delivery system

On free blowing applications the integrity of the fastenings on the heater top and outlet nozzles must be checked .

Final adjustment for the direction of the air

flow from the nozzle hoods should be made, and the hoods should be secured in the required position by drilling through the two holes provided in the hood outer ring and fastened in place using self tapping screws .

Caution

On ducted applications it is necessary that the system is balanced in order to optimise the efficiency of the heater and the air distribution and delivery system Failure to balance the system can result in fan motor overloading and premature component failure, it can also result in an inefficient heating/ventilation system.

(a) Check that the amount of fan produced air volume is in accordance with the heater specification, if the volume is too great the fan can be overloaded.

Ensure that the running current is as per that stated on the heater data plate.

Alternatively, the static pressure should be measured at the start of the ductwork to confirm that it is within the permissible tolerance.

(b) If the current drawn is greater than the stated running current, in most probability this will be caused by insufficient static pressure within the ductwork, in which case system resistance should be increased through the introduction of a damper placed as close to the start of the ductwork as possible, thereby resulting in a reduction in drawn current.

The damper should be adjusted until the current is in accordance with that stated on the data plate.

(c) If the current drawn is too low the duct outlet grilles will require opening to reduce static pressure and increase air volume, if this is not the case overheat cut outs can be caused.

The Fan Belts must be rechecked on completion of commissioning ensuring that the tension is correct and the pulleys are in alignment

4.4 Commissioning - hand over

(a) Upon full and satisfactory completion of commissioning, a record of commissioning

information (contact, date, etc) should be left with the heater, a copy of which must also be forwarded to Benson Heating Service Department.

(b) The commissioning engineer must ensure that the user is familiar with the safe and efficient use of the heater, detailing the function of all controls, and main components.

(c) The user should be made aware of the following in particular

(i) Lighting, shutdown, and operational information.

(ii) Safety features, data plate, and labelling.

(iii) The requirement for regular inspection - especially if the heater is within a more demanding environment - and the need for regular servicing carried out by competent and qualified persons.

(d) Section C 'User Instructions' should be left with the customer upon satisfactory completion of the commissioning and hand-over.

Caution

After approximately 100 hours of running, the tension of the fan belts must be checked to ensure that they are correct and that they have not stretched. See section 5.2 for further instructions.

**Turbulator Positions in Heat Exchanger
800-1000 Oil Cabinets 12 off**

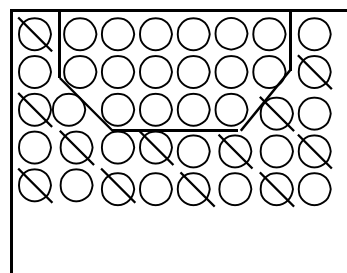

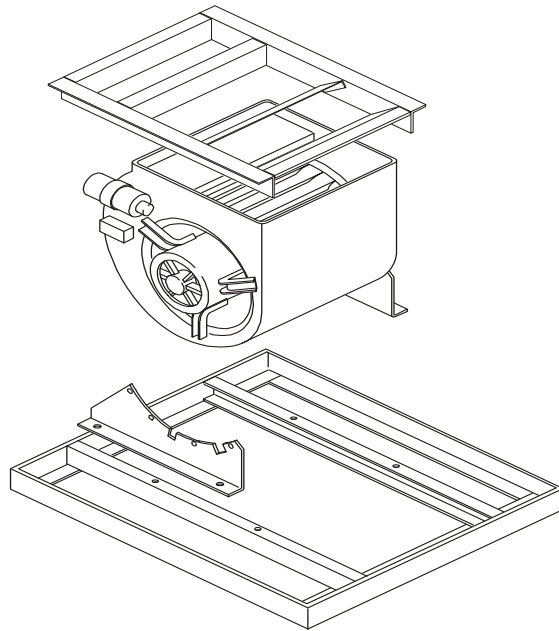

Motorised Fan
Assembly

100 — 300

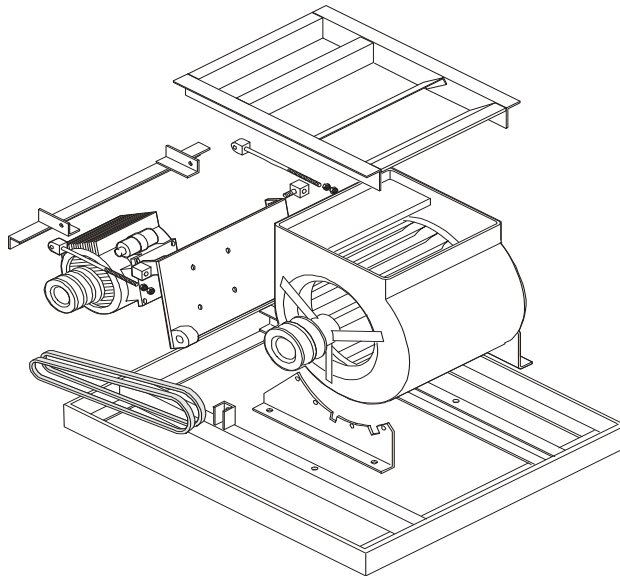

Fan and Motor
Assembly

400 — 700

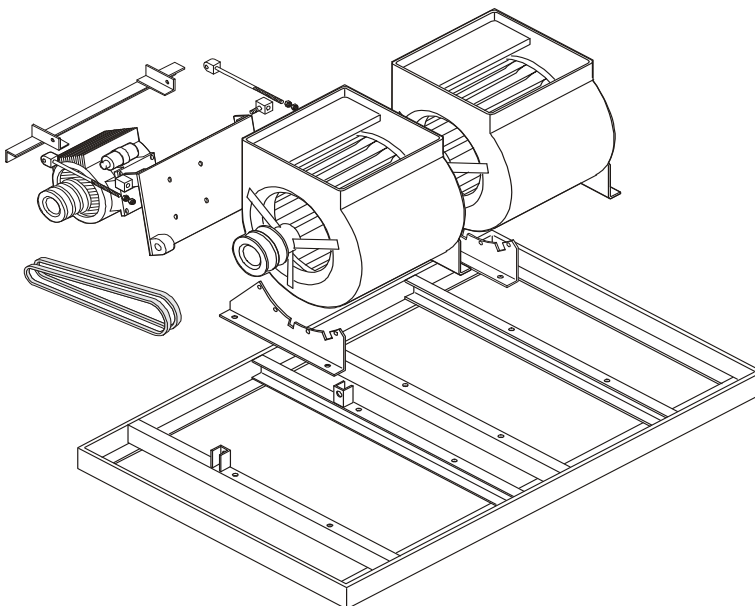

Fan and Motor
Assembly

800—1300

5.0 Servicing

Warning

Servicing must be carried out on a regular basis, the maximum interval between services being 1 year. It is a requirement that only suitably qualified and competent persons are allowed to undertake servicing.

Before any maintenance or servicing work is carried out the heater must be shut down and allowed to cool, and have the oil and electric supplies to it turned off at the supply valve and isolator respectively.

Caution

Certain component parts are factory sealed and are designed so as to be tamper proof. Usually such items do not require servicing, and therefore should not be tampered with. Failure to comply with this can invalidate any warranty, and can also lead to premature failure.

The following parts fall within this category: room thermostat, time clock, frost thermostat, sequential controller, and fan and motor. Additionally, the fan and limit stat has been factory set, and must not be re-set without formal consent from the manufacturer.

Reference should be made to the separate information covering the operational details of the burner and timer.

Only approved spare/replacement parts can be fitted, failure to comply with this can compromise the safe and efficient running of the heater, and can also invalidate any warranty claim.

5.1 Planned Servicing

In order to maintain the efficient operation of the heater it is recommended that the following planned servicing and preventative maintenance programme is adopted by the user.

Quarterly Inspection

- (a) Visual inspection of the burner
- (b) Clean and check spark electrode
- (c) Clean and check photocell
- (d) Check overheat safety is operational

Bi-Annual Inspection

- (a) As per quarterly inspection, plus...
- (b) Combustion check

- (c) Smoke test

Annual Inspection

- (a) As per half year inspection, plus...
- (b) Heat exchanger and cleaning
- (c) Electrical connections
- (d) Main fan motor
- (e) Main fan assembly
- (f) Pulleys
- (g) Fan belts
- (h) Oil supply including filter
- (i) Burner
- (j) Air delivery system
- (k) Flue
- (l) Report

5.2 Servicing Procedure - Major Component Parts

Flue

A visual inspection should be carried out to ensure that the flue remains adequately supported, both internally as well as externally, and that the various joints are effectively sealed. Inspection covers, where fitted, should be removed and the flue checked to see whether cleaning is required. If inspection covers are not fitted the flue gas exit duct and flue spigot will provide not only an indication of the cleanliness of the flue, but will also enable access for cleaning. The presence of the flue terminal should be checked. If a condensate trap and drain facility is fitted this should be checked to ensure that it continues to function correctly, and the drainage of condensates is not impaired.

Main Fan Motor

Remove access panel. Dust and other foreign matter should be cleaned by blowing over with compressed air and through the use of a soft bristle brush and cloth. Solvent wipes may be used to remove heavy soiling from the motor casing.

Traces of surplus lubricants spreading from the bearings should also be cleaned away. Where motors are fitted with grease nipples bearings should be lubricated with the correct grade of lubricant. Motors which do not have grease nipples feature sealed bearings which are lubricated during manufacture for their life.

The electrical connections should be checked as follows.

The cover to the terminal box should be

removed by undoing the screws which secure it.

Check connections for signs of corrosion, tightness, and ensure that there are no stray strands which could form a short circuit. Clean, tighten, and replace as necessary. Replace cover and secure.

Main Fan

Remove dust and other foreign matter by blowing off with compressed air or through the use of a soft bristle brush.

Check that the bearings do not show signs of excessive wear.

It should be noted that these bearings do not require lubricating.

If the bearings require replacing the following procedure should be followed.

- (a) Remove belt(s).
- (b) Loosen set screw on eccentric collar and tap collar in the opposite direction to fan rotation.
- (c) Remove collar and bearing.
- (d) Check shaft for alignment and straightness.
- (e) Locate the bearing in its seat and place on the shaft with the cam facing outwards.
- (f) Fit the eccentric collar and engage the cams.
- (g) Tighten initially by rotating, and then by tapping in the direction of the fan rotation.
- (h) Replace fasteners and secure.
- (i) Turn by hand to ensure free fan rotation.

Pulleys

Check pulleys for alignment using a straight edge, if necessary reposition either or both of the pulleys and the fan motor.

Check for excessive wear within the root and sides of the grooves, and check for any other signs of wear or damage, if necessary replace the pulley as follows.

- (a) Release tension on belts and remove.
- (b) Release the taper locks by slackening the securing screws by several complete turns.
- (c) Fully remove one screw from the taper lock, and having oiled it, insert into the threaded jacking point.
- (d) Tighten screw until the taperlock is free.
- (e) Remove taperlock and pulley.
- (f) Fit taperlock in new pulley, and provisionally position on the shaft.

(g) Remove the screw from the jacking point, and tighten both screws in their clamping points until the pulley can just be moved on the shaft by hand.

(h) Align pulleys using a straight edge, and by gradual alternate tightening of the screws clamp in position.

(i) Refit belts and check for the correct amount of tension.

Fan Belts

Check belts for signs of wear.

Frayed or split belts must be replaced using belts with a common batch code.

Belt tension must be checked, and if on multi-belt units it is found that one belt contains more slack than its accompanying belts, then all the belts on the unit must be replaced, again using a common batch code. Replacement and tensioning is carried out as follows.

Note

The maximum displacement at the mid point of the top edge of the belt must not be greater than 16mm per metre of span, when a force of 3kg is applied in a plane perpendicular to the belt.

- (a) Loosen fan motor securing bolts on chassis.
- (b) Loosen fan motor slide adjustment bolt.
- (c) Slide fan motor towards fan to slacken belts.
- (d) Replace belts, pull fan motor away from fan until belts are tight.
- (e) Tighten adjustment bolt to hold motor.
- (f) Tighten fan securing bolts ensuring that the fan is square and the pulleys aligned.
- (g) Check belt tension, making final adjustments as necessary.
- (h) Tighten and clamp fasteners to hold fan motor in position.

Heat Exchanger

The heat exchanger requires a visual inspection at least once per year, this should be accompanied by cleaning. It is recommended that a flue brush and vacuum cleaner be used to facilitate this. Access to the heat exchanger is gained through the removal of the rear upper panel and heat shield.

Servicing and cleaning should be performed as follows.

(a) Remove brass nuts and cover from heat exchanger end assembly to expose heat exchanger tubes.

(b) Remove any accumulated deposits from the tubes by pushing through the full length with a flue brush.

(c) The flue brush should be withdrawn so as to pull any deposits back into the bottom of the flue box where they can then be removed by using a vacuum cleaner.

(d) Particular attention should be paid to the upper internal surfaces of the tubes, where through convection heavier deposition is likely to occur.

(e) Any deposits which may have accumulated within the combustion chamber can be removed with a vacuum cleaner once the burner is removed.

Note

It is most important that a build up of deposits is not allowed to occur as this can have an adverse effect upon the efficiency of the heater and reduce the life of the heat exchanger.

(f) The heat exchanger and combustion chamber should be visually inspected for signs of splits, cracks, and distortion.

(g) All gaskets should be checked to ensure that they continue to provide a gas tight seal, if there is an element of doubt then they should be replaced.

If the condition of the heat exchanger gives cause for concern the Service Department at Benson Heating should be advised pending a more detailed examination

Electrical Supply

All connections must be checked to ensure that they are secure, and free from corrosion. Terminals and connections should also be checked to ensure that no stray strands are bridging terminals.

Electrical continuity should also be checked.

Oil Supply

The oil supply pipe work, tank, and fittings should all be inspected to ensure that they are free from corrosion, and to ensure that where brackets have been fitted these remain secure and offer adequate support.

The oil filter should be replaced with a new one, and the system should be checked for leaks. If the oil level is such to allow removal of any sludge or other contaminants from the tank this too should be undertaken, particularly if there have been problems of poor firing associated with contaminants reaching the burner.

Note

Any waste oil or sludge must be disposed of correctly. Never dispose of it by dumping or tipping it down drains or into watercourses where ground water can become polluted and environmental damage caused.

Burner

Service requirements for the burner fitted to the cabinet heater are covered in the separate manual prepared by the burner manufacturer.

Note

It is most important that the burner is serviced regularly and in accordance with the manufacturers instructions.

Air Delivery System

A visual inspection should be undertaken to ensure that the air delivery system is in good order, that it remains adequately supported and that the various joints are effectively sealed.

Report

A full and detailed service report should be prepared, it is advised that the report is not completed until the heater has been re-commissioned, where upon the completed report can then be run through with the user.

5.3 Service Re-commissioning

The heater should be re-commissioned as follows, as per section 4.1 through to section 4.4 inclusive. This must be regarded as a necessary part of the heater service. By the service engineer.

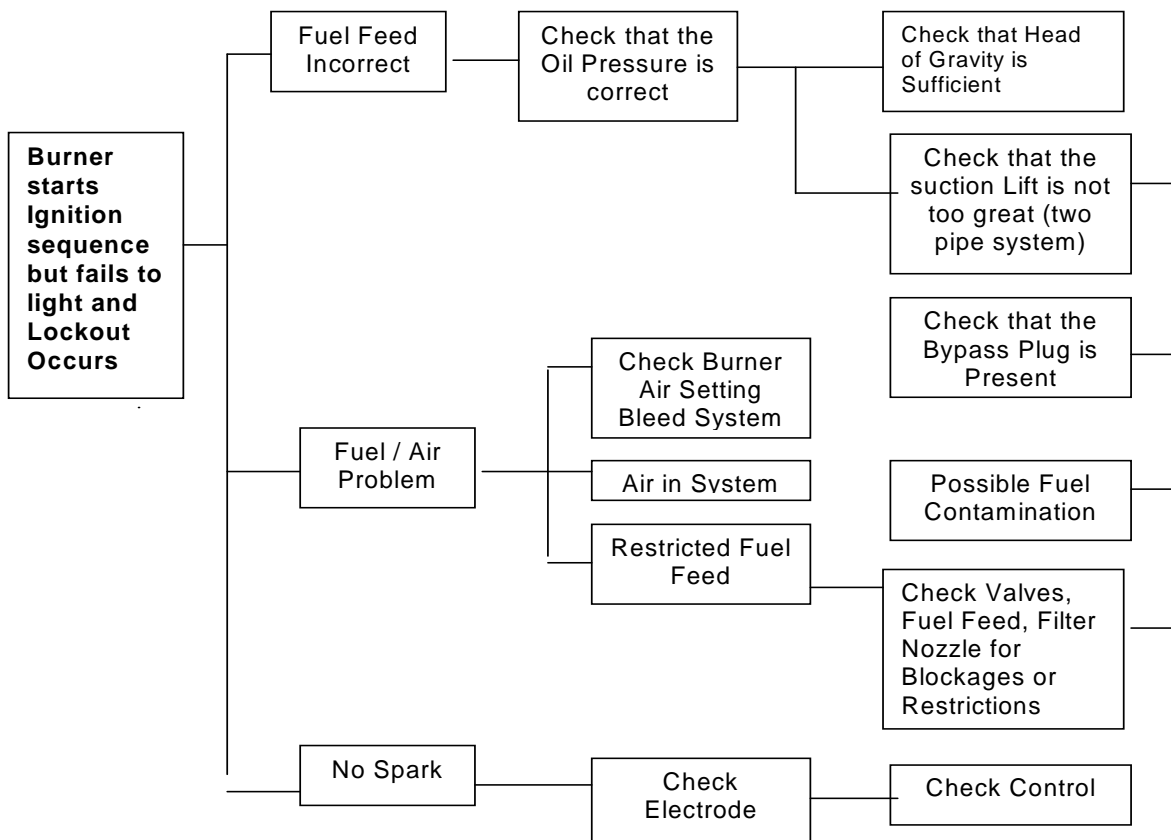
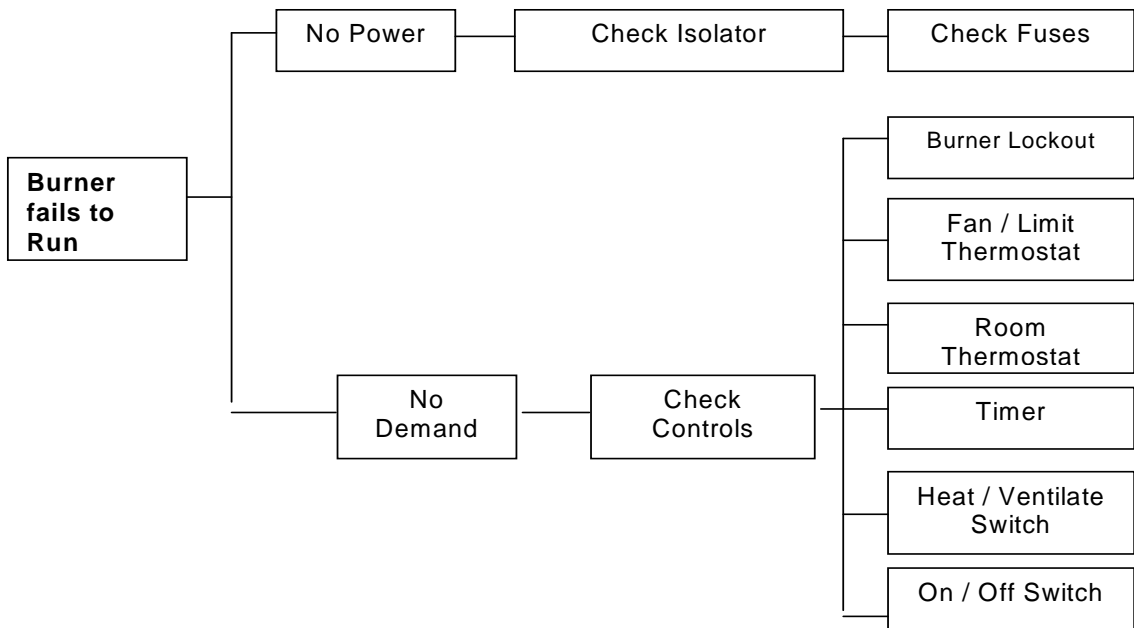

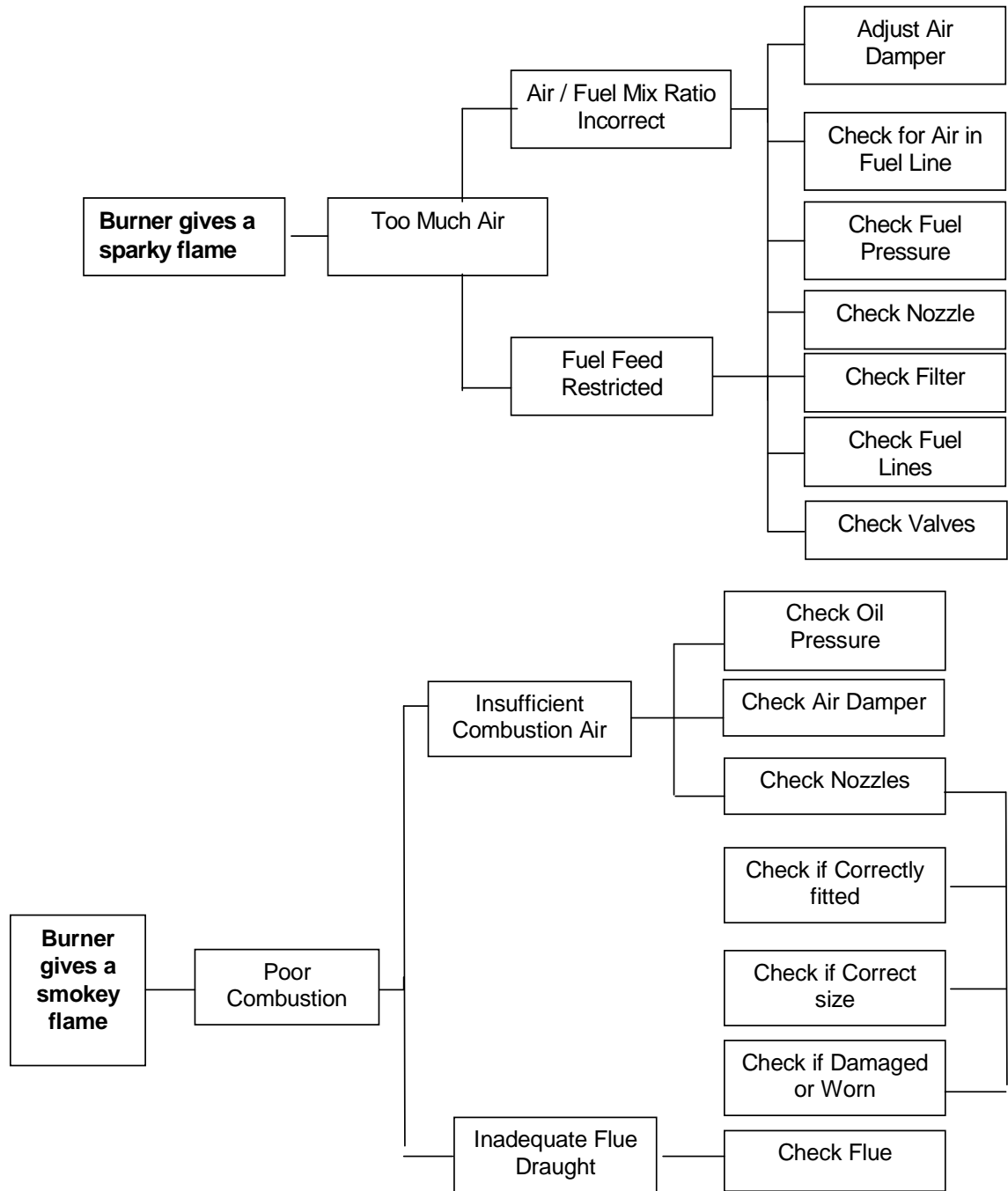

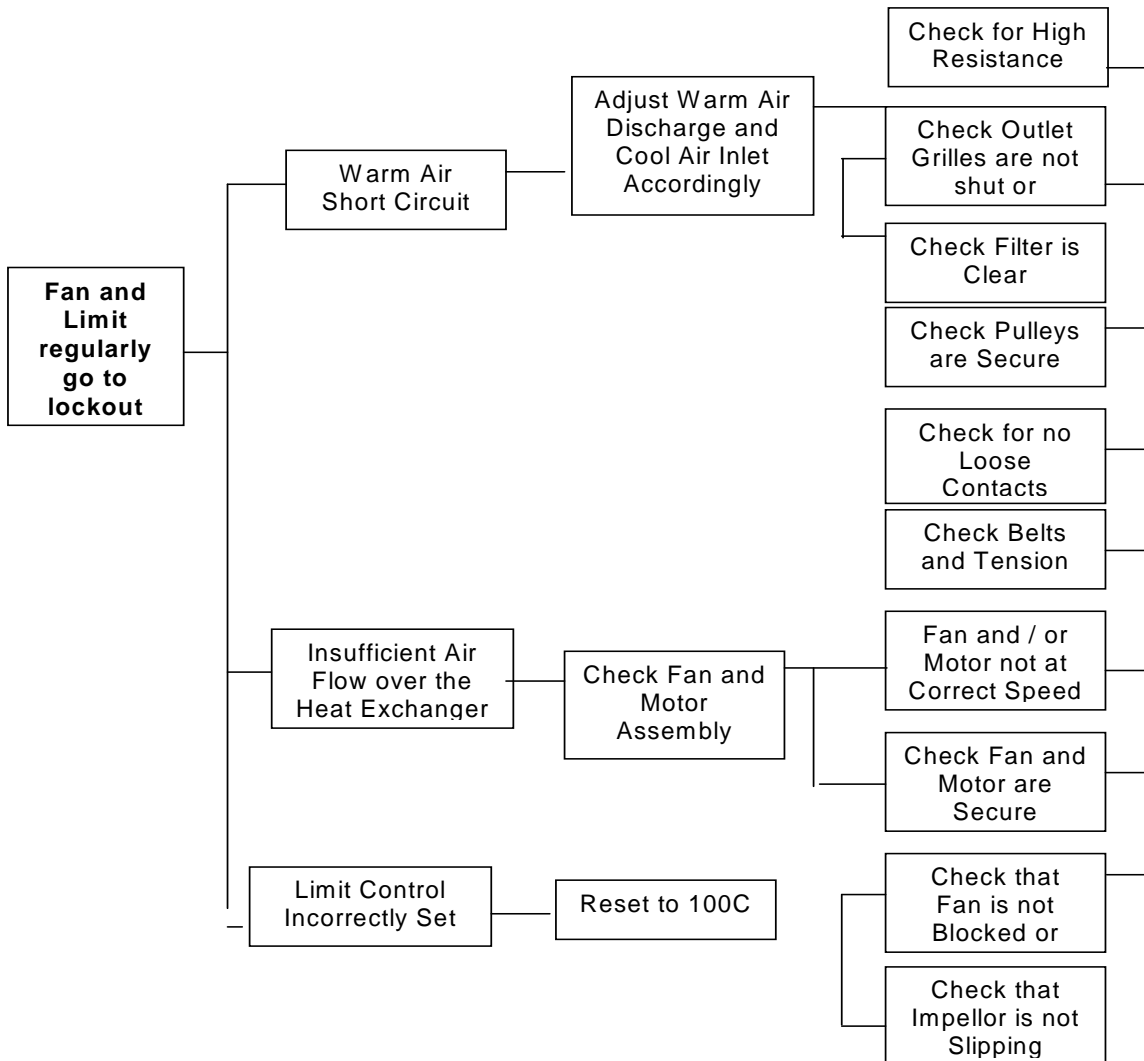
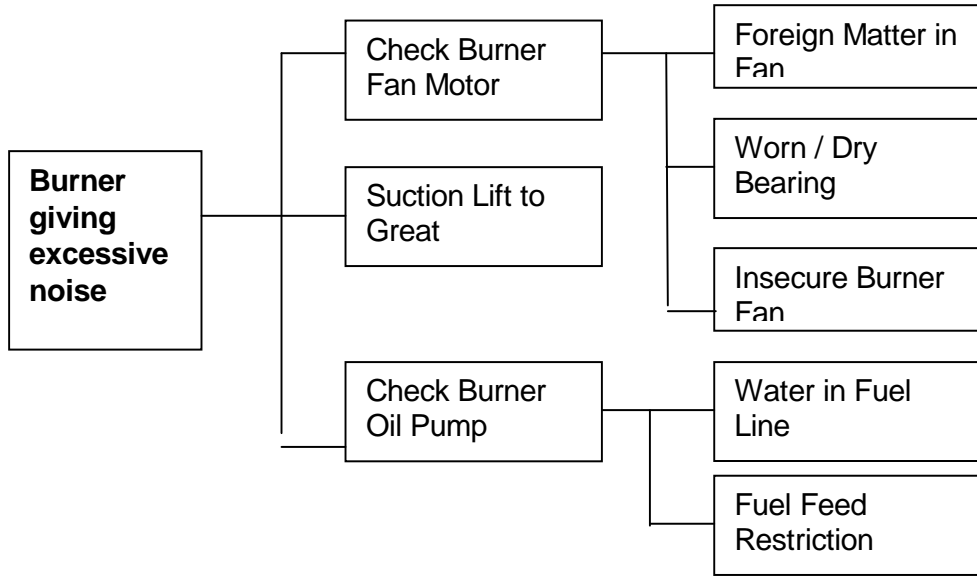

Drawing No 28-45-181

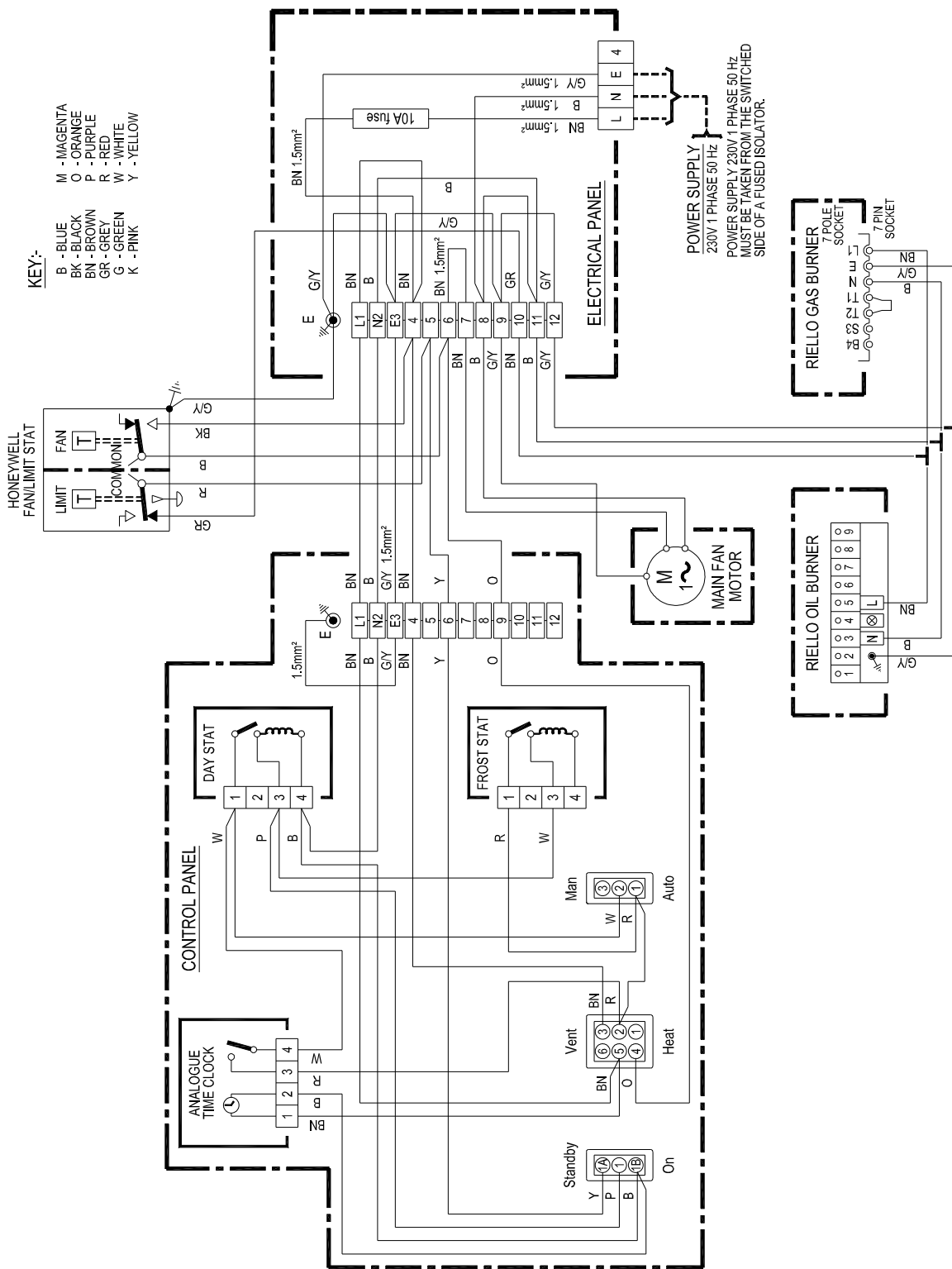

**100 – 300 Riello ON / OFF Gas or Oil Fired Burner
230v/1ph/50Hz Analogue Control**

Drawing No 20-45-182

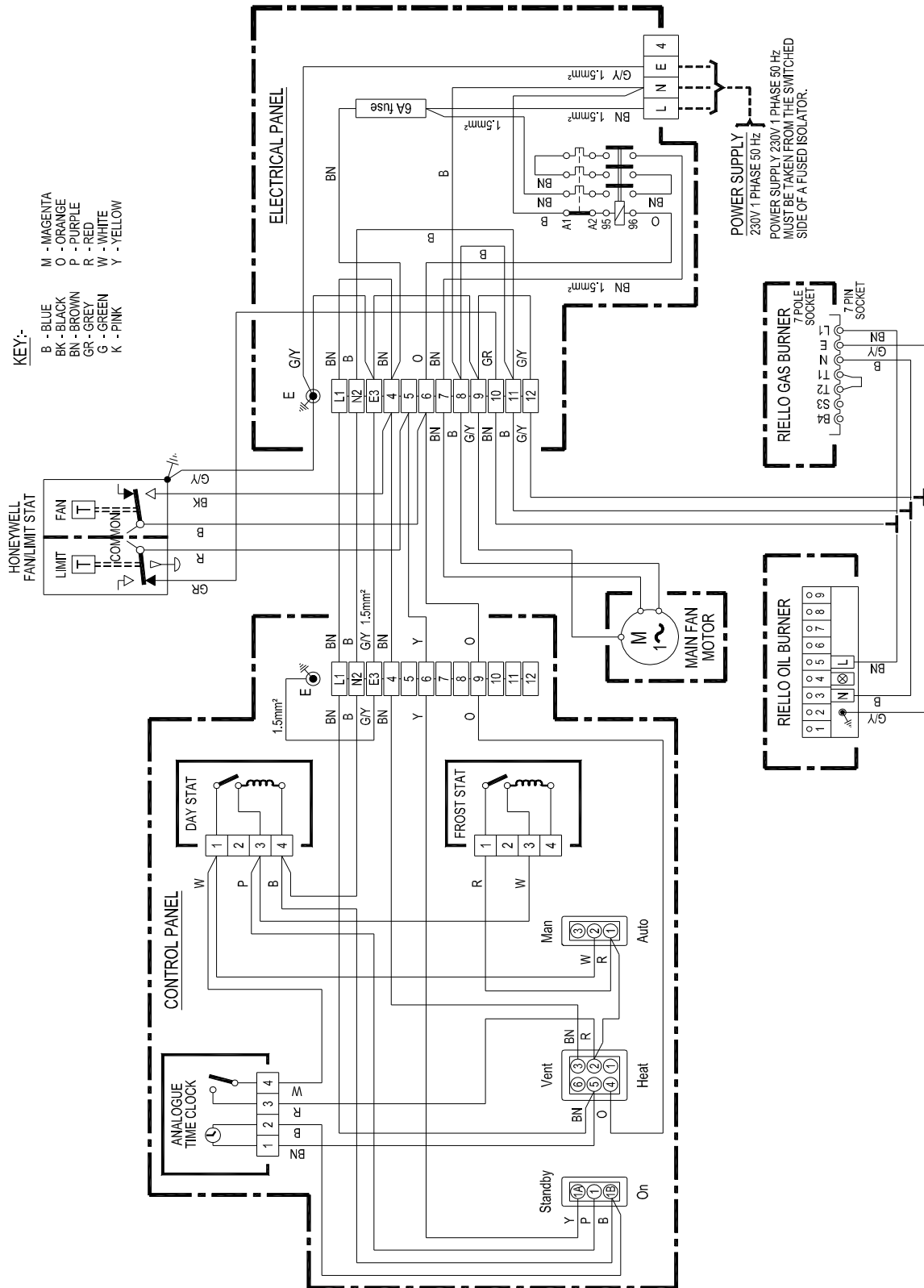

**400 – 500 Riello ON / OFF Gas or Oil Fired Burner
230v/1ph/50Hz Analogue Control**

Drawing No 20-45-312

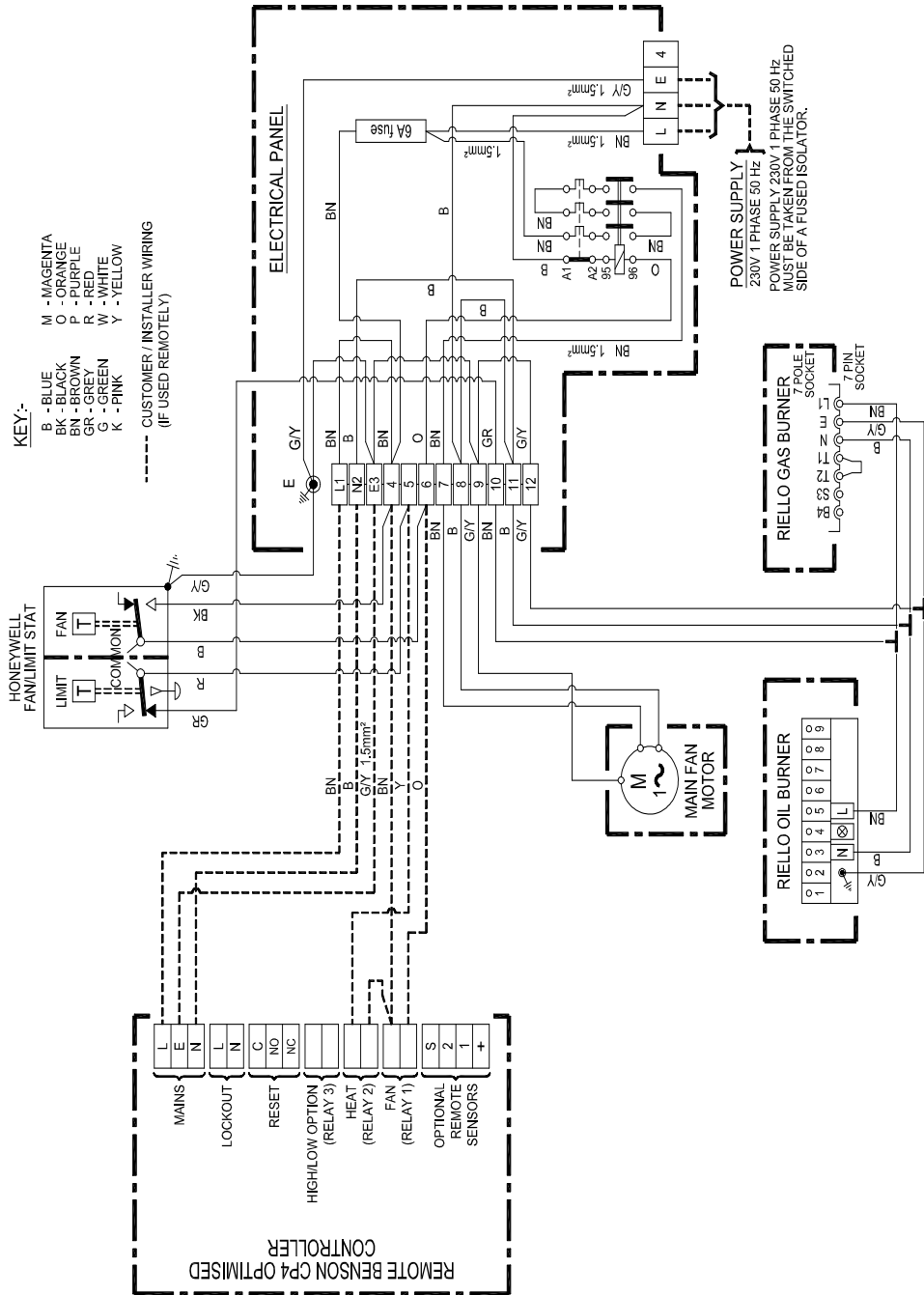

400 – 500 Riello ON / OFF Gas or Oil Fired Burner 230v/1ph/50Hz CP4 Control

Drawing No 20-45-183

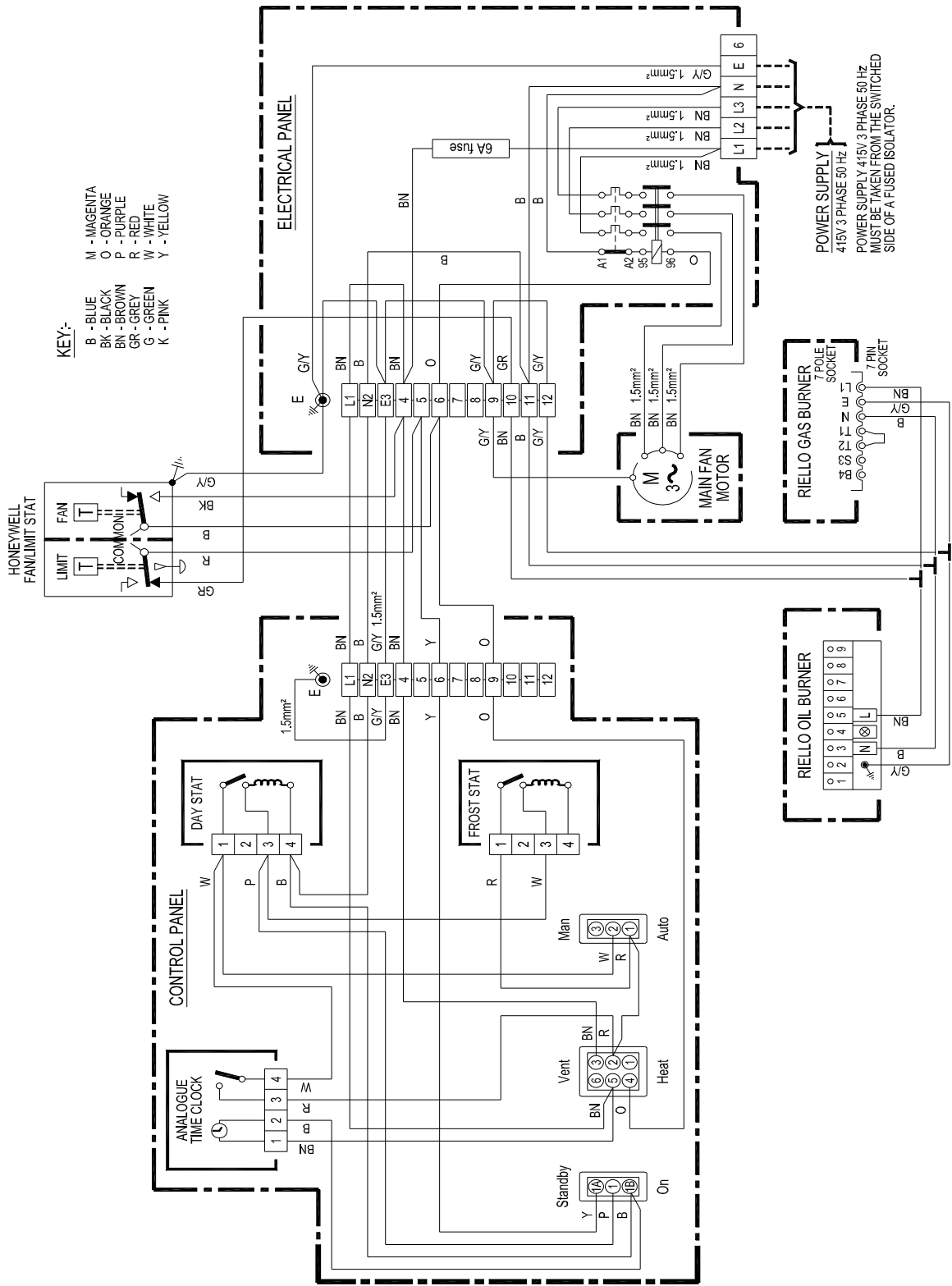

**200 – 1000 Riello ON/OFF Gas or Oil Fired Burner
 415v/3ph/50Hz Analogue Control**

Drawing No 20-45-313

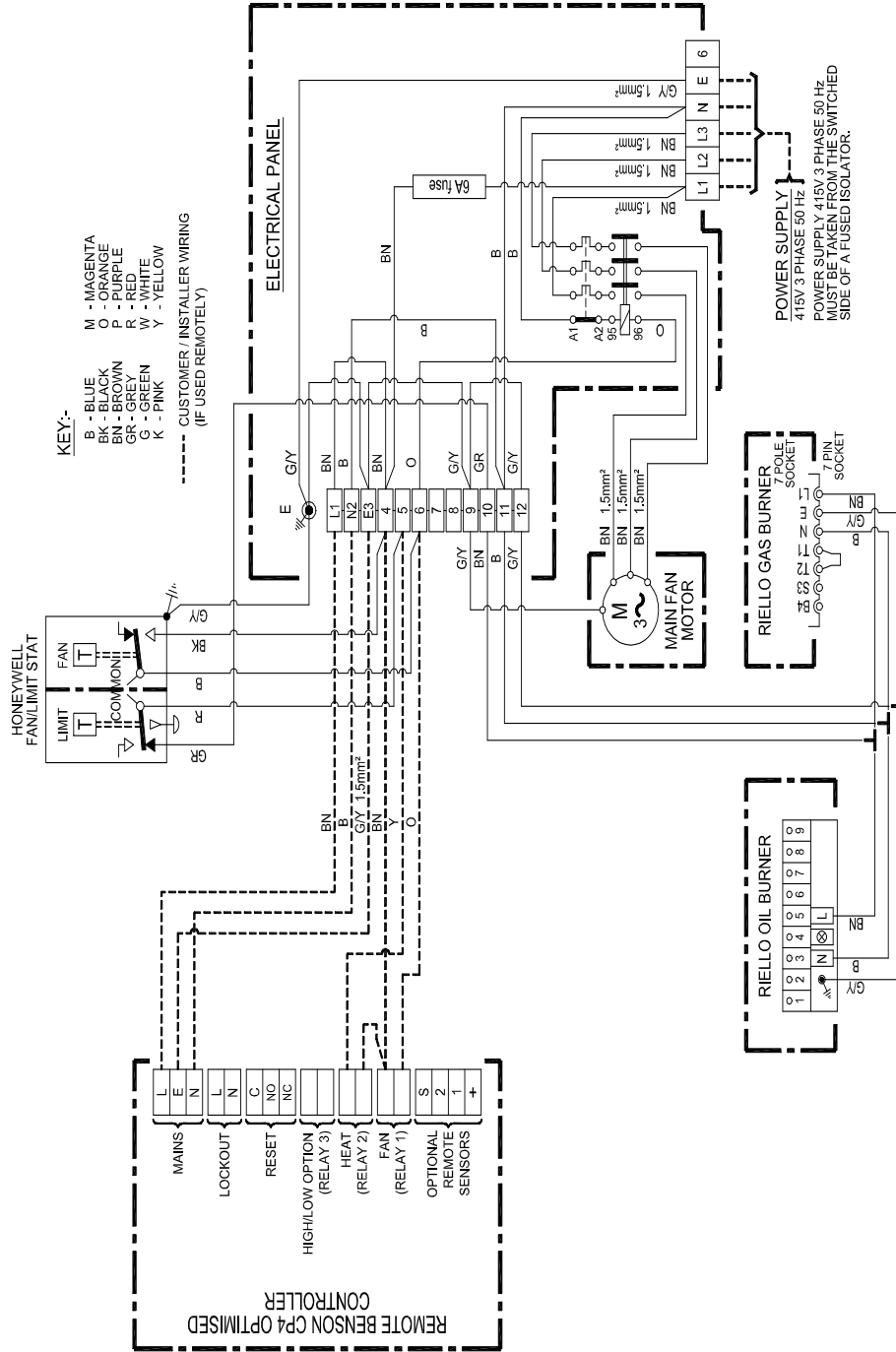

200 – 1000 Riello ON/OFF Gas or Oil Fired Burner 415v/3ph/50Hz CP4 Control

8.1 Technical Data

MODEL		100	125	150	200
HEAT OUTPUT	kW/hr Btu/hr	29.16 99,500	36.21 123,500	43.32 147,800	57.96 197,800
HEAT INPUT (GROSS)	kW/hr Btu/hr	35.40 120,800	44.09 150,500	54.10 184,500	70.31 239,900
GROSS EFFICIENCY	%	82.62	82.36	80.30	82.66
FUEL CONSUMPTION Gas Oil 35'	Imp gall/hr litre/hr	0.73 3.3	0.92 4.2	1.10 5.0	1.45 6.6
BURNER TYPE	RIELLO	G 5	G 5	G.5	G 10
GAS OIL NOZZLE	US galls/hr Type	0.65 80°S	0.85 60°S	1.0 60°S	1.35 60°S
GAS OIL PRESSURE	Psi Bar	180 12.2	170 11.6	180 12.2	170 11.6
HEAD SETTING 35'oil zero flue resistance	Number	2	3	4	2.5
AIR SETTING 35' oil zero flue resistance	Number	3.2	4.5	5	3
OIL CONNECTION	BSP	3/8	3/8	3/8	3/8
AVAILABLE OUTLET PRESSURE (STD)	Pascals Ins WG	75 0.3	100 0.4	100 0.4	75 0.3
NOZZLE DISCHARGE VELOCITY	m/sec ft/min	5.73 1124	4.53 888	4.53 888	6.57 1288
AIR THROW (APPROX)	mtrs Ft	14 45	14 45	14 45	17.1 55
AIR DELIVERY (STD)	m ³ /sec Ft ³ /min	0.61 1300	0.71 1500	0.71 1500	1.03 2180
TEMPERATURE RISE THROUGH HEATER	Deg C Deg F	39 70	41.9 75	50.3 90	46.3 82
SOUND LEVEL	DbA	67	69	69	72
COMBUSTION CHAMBER (press)	m/Bar	0.09	0.14	0.14	0.12
FLUE RESISTANCE	Min m/bar Max m/bar	-0.2 0.6	-0.2 0.6	-0.2 0.6	-0.2 0.6
FLUE DIAMETER	mm	125	125	125	150
ELECTRICAL SUPPLY	Standard	230/1/50	230/1/50	230/1/50	230/1/50
RATED INPUT	kW	0.55	0.55	0.55	1.1
FUSED ISOLATOR SIZE	Amps	16	16	16	20
RUNNING CURRENT	Amps	3.2	4.8	4.8	6
ELECTRICAL SUPPLY	Optional	N/A	N/A	N/A	415/3/50
RATED INPUT	KW	N/A	N/A	N/A	0.75
FUSED ISOLATOR SIZE	Amps	N/A	N/A	N/A	16
RUNNING CURRENT	Amps	N/A	N/A	N/A	2.2
NETT WEIGHT	Kg	196	196	196	241
ELECTRICAL PROTECTION	IP	20	20	20	20
A1R NOZZLE SIZE	Ins	9.4	9.4	9.4	9.4
NOZZLE AMOUNT	No	2	2	2	2
FLUE TEMP (GROSS)	@ 20° C Ambient	245	265	285	250

Technical Data Cont'd

MODEL		250	300	400	500
HEAT OUTPUT	kW/hr Btu/hr	73.00 249,000	86.05 293,600	117.02 399,300	132.16 450,900
HEAT INPUT (GROSS)	kW/hr Btu/hr	88.83 303,000	107.12 365,500	142.78 487,200	161.23 550,100
GROSS EFFICIENCY	%	82.41	80.56	82.19	82.20
FUEL CONSUMPTION Gas Oil 35'	Imp gall/hr litre/hr	1.9 8.6	2.2 10.0	3.0 13.6	3.3 15.2
BURNER TYPE	RIELLO	G 10	G10	G20	G20S
GAS OIL NOZZLE	US galls/hr Type	1.75 60°S	2.0 60°S	2.75 60°S	3.0 60°S
GAS OIL PRESSURE	Psi Bar	170 11.6	180 12.2	170 11.6	180 12.2
HEAD SETTING 35'oil zero flue resistance	Number	4.0	5	3	3
AIR SETTING 35'oil zero flue resistance	Number	3.8	4.5	3.6	6
OIL CONNECTION	BSP	3/8	3/8	3/8	3/8
AVAILABLE OUTLET PRESSURE (STD)	Pascals Ins WG	100 0.4	100 0.4	137 0.55	150 0.6
NOZZLE DISCHARGE VELOCITY	m/sec ft/min	5.91 1159	5.91 1159	7.55 1481	6.98 1369
AIR THROW (APPROX)	mtrs ft	17.1 55	17.1 55	20.2 65	20.2 65
AIR DELIVERY (STD)	m ³ /sec ft ³ /min	1.39 2950	1.39 2950	2.15 4550	2.65 5620
TEMPERATURE RISE THROUGH HEATER	Deg C Deg F	42.8 77	49.8 90	45.1 81	44.5 79
SOUND LEVEL	DbA	72	72	74	76
COMBUSTION CHAMBER (press)	m/bar	0.23	0.23	0.56	0.88
FLUE RESISTANCE	Min m/bar Max m/bar	-0.2 0.6	-0.2 0.6	-0.2 0.6	-0.2 0.6
FLUE DIAMETER	mm	150	175	175	175
ELECTRICAL SUPPLY	Standard	230/1/50	230/1/50	415/3/50	415/3/50
RATED INPUT	kW	1.1	1.1	1.5	2.2
FUSED ISOLATOR SIZE	Amps	20	20	16	16
RUNNING CURRENT	Amps	7.2	7.2	3.6	5.2
ELECTRICAL SUPPLY	Optional	415/3/50	415/3/50	230/1/50	230/1/50
RATED INPUT	KW	0.75	0.75	1.5	2.2
FUSED ISOLATOR SIZE	Amps	16	16	40	40
ELECTRICAL PROTECTION	IP	20	20	20	20
RUNNING CURRENT	Amps	2.2	2.2	12	14
WEIGHT	Kg	243	243	330	332
A1R NOZZLE SIZE	Ins	9.4	9.4	11	11
NOZZLE AMOUNT	No	3	3	3	4
FLUE TEMP (GROSS)	@ 20° C Ambient	295	320	280	300

Technical Data cont'd

MODEL		600	700	800
HEAT OUTPUT	kW/hr Btu/hr	176.59 602,500	204.99 699,400	234.96 801,700
HEAT INPUT (GROSS)	kW/hr Btu/hr	214.22 730,900	255.72 872,500	285.70 974,800
GROSS EFFICIENCY	%	82.66	80.39	82.24
FUEL CONSUMPTION Gas Oil 35'	Imp gall/hr litre/hr	4.47 20.3	5.3 24.1	5.9 27.1
BURNER TYPE	RIELLO	G20S	RL28.1	RL28.1
GAS OIL NOZZLE	US galls/hr Type	4.0 60°S	2.75&2.0 60°S	3.0 & 2.5 60°S
GAS OIL PRESSURE	Psi Bar	180 12.2	180 12.2	170 11.6
HEAD SETTING 35'oil zero flue resistance	Number	6	TBA	TBA
AIR SETTING 35'oil zero flue resistance	Number	7	TBA	TBA
OIL CONNECTION	BSP	3/8	3/8	3/8
AVAILABLE OUTLET PRESSURE (STD)	Pascals Ins WG	175 0.7	188 0.75	125 0.5
NOZZLE DISCHARGE VELOCITY	m/sec ft/min	6.13 1203	6.71 1315	6.55 1285
AIR THROW (APPROX)	mtrs ft	20.2 65	21.7 70	21.7 70
AIR DELIVERY (STD)	m ³ /sec ft ³ /min	3.11 6600	3.4 7200	4.32 9150
TEMPERATURE RISE THROUGH HEATER	Deg C Deg F	44.7 81	49.2 90	44.2 79
SOUND LEVEL	DbA	78	78	79
COMBUSTION CHAMBER (press)	m/Bar	0.54	0.62	0.89
FLUE RESISTANCE	Min m/bar Max Mbar	-0.2 0.6	-0.4 1.6	-0.4 1.6
FLUE DIAMETER	mm	200	200	225
ELECTRICAL SUPPLY	Standard	415/3/50	415/3/50	415/3/50
RATED INPUT	kW	3	3	4
FUSED ISOLATOR SIZE	Amps	25	25	32
RUNNING CURRENT	Amps	6.5	6.5	8.4
ELECTRICAL SUPPLY	Optional	N/A	N/A	N/A
RATED INPUT	KW	N/A	N/A	N/A
FUSED ISOLATOR SIZE	Amps	N/A	N/A	N/A
ELECTRICAL PROTECTION	IP	20	20	20
RUNNING CURRENT	Amps	N/A	N/A	N/A
WEIGHT	Kg	525	540	360
A1R NOZZLE SIZE	Ins	12.6	12.6	14.6
NOZZLE AMOUNT	No	4	4	4
FLUE TEMP (GROSS)	@ 20° C Ambient	285	320	295

Technical Data Cont'd

MODEL		1000	1200	1300
HEAT OUTPUT	kW/hr Btu/hr	283.67 967,900	349.98 1194,100	380.45 1298,100
HEAT INPUT (GROSS)	kW/hr Btu/hr	345.88 1180,150	426.66 1455,800	470.08 1603,900
GROSS EFFICIENCY	%	82.24	82.26	81.16
FUEL CONSUMPTION Gas Oil 35sec	Imp gall/hr litre/hr	7.26 33.0	8.26 37.5	9.80 44.5
BURNER TYPE	RIELLO	RL28.1	RL38.1	RL50
GAS OIL NOZZLE	US galls/hr Type	4.0 & 2.5 60°S	4.0 & 3.0 60°S	5.0 & 4.0 60°S
GAS OIL PRESSURE	Psi Bar	180 12.2	200 13.8	170 11.6
HEAD SETTING 35'oil zero flu resistance	Number	TBA	TBA	TBA
AIR SETTING 35'oil zero flu resistance	Number	TBA	TBA	TBA
OIL CONNECTION	BSP	3/8	3/8	3/8
AVAILABLE OUTLET PRESSURE (STD)	Pascals Ins WG	175 0.7	250 1	250 1
NOZZLE DISCHARGE VELOCITY	m/sec ft/min	7.39 1445	8.49 1665	8.49 1665
AIR THROW (APPROX)	mtrs ft	24.8 80	31.1 100	31.1 100
AIR DELIVERY (STD)	m ³ /sec ft ³ /min	4.86 10,300	6.88 14,680	6.88 14,680
TEMPERATURE RISE THROUGH HEATER	Deg C Deg F	48 86	40.2 72	45 81
SOUND LEVEL	DbA	81	81	81
COMBUSTION CHAMBER (press)	m/Bar	1.21	0.9	0.9
FLUE RESISTANCE	Min m/bar Max Mbar	-0.4 1.6	-0.4 1.6	-0.4 1.6
FLUE DIAMETER	mm	225	250	250
ELECTRICAL SUPPLY	Standard	415/3/50	415/3/50	415/3/50
RATED INPUT	kW	5.5	7.5	7.5
FUSED ISOLATOR SIZE	Amps	32	64	64
ELECTRICAL PROTECTION	IP	20	20	20
RUNNING CURRENT	Amps	11	17	24
WEIGHT	Kg	646	1090	1090
A1R NOZZLE SIZE	Ins	14.6	18.5	18.5
NOZZLE AMOUNT	No	4	4	4
FLUE TEMP (GROSS)	@ 20° C Ambient	320	255	285

9.0 Reference Information

Doc/Ref		Title/Subject
BS 5410	Part 1 ; 1977 and Part 2 ; 1978	Code of Practice for Oil firing
BS EN 292	Parts 1 and 2; 1992	Safety of Machinery
BS EN 60204	Part 1; 1993	Safety of Machinery - Electrical
BS EN 60335	Part 1; 1988	Safety of Electrical Appliances
BS EN 55014	1993	Electromagnetic Compatibility
BS EN 50165	1997	Safety of Electrical Equipment
BS 5854	1980	Code of Practice - Flues/Flue Structures
BS 799	Part 5 ; 1987	Oil Burning Equipment - oil tanks
OFTEC	OFS T-100	Polyethylene oil storage tanks
BS 715	1993	Metal Flue Pipes and Fittings
BS 5440	Part 1 ; 1990	Specification/Installation of Flues
BS 5440	Part 2 ; 1989	Ventilation Requirement Gas Appliances
BS 779	Part 2 ; 1991	Oil Burning Equipment - Burners
ISO 228/1	See also BS 2779 and BS 5380)	Pipe Threads Seals and Couplings

9.1 Parts List

DESCRIPTION	100	125	150	200	250
Stackbox Assy	31-28-078	31-28-078	31-28-078	31-24-074	31-24-074
Fan/Limit Thermostat	28-60-023	28-60-023	28-60-023	28-60-021	28-60-021
Fan/ limit Stat Gasket	20-33-549	20-33-549	20-33-549	20-33-549	20-33-549
Burner Plate Gasket	31-28-080	31-28-080	31-28-080	30-40-156	30-40-156
Pressure Relief Gasket	3127-121	31-27-121	31-27-121	31-27-121	31-27-121
Sight Glass	20-30-151	20-30-151	20-30-151	20-30-151	20-30-151
Time Clock	28-15-008	28-15-008	28-15-008	28-15-008	28-15-008
Thermostat Room	28-16-031	28-16-031	28-16-031	28-16-031	28-16-031
Thermostat Frost	28-16-044	28-16-044	28-16-044	28-16-044	28-16-044
Rocker Switch Red Neon	28-40-105	28-40-105	28-40-105	28-40-105	28-40-105
Rocker Switch Dual Black	28-40-106	28-40-106	28-40-106	28-40-106	28-40-106
Rocker Switch Black	28-40-104	28-40-104	28-40-104	28-40-104	28-40-104
Fuse 1ph	28-07-049	28-07-049	28-07-049	28-07-049	28-07-049
Motorised Fan 1ph	28-09-049	28-09-049	28-09-049	28-09-002	28-09-002
Fan Restrictor	31-30-017	N/A	N/A	31-30-016	N/A
Fire Check Valve	28-30-102	28-30-102	28-30-102	28-30-102	28-30-102
Fuel Filter	29-15-017	29-15-017	29-15-017	29-15-017	29-15-017
Nozzle	27-00-413	27-00-415	27-00-418	27-00-427	27-00-433
Burner	29-99-452	29-99-452	29-99-452	29-99-453	29-99-453
Control	CP4	CP4	CP4	CP4	CP4

DESCRIPTION	300	400	500	600	700
Stackbox Assy	31-27-123	31-27-123	31-27-123	20-46-307	20-46-307
Flue Box Cover Assy	20-45-094	20-45-094	20-45-094	20-46-310	20-46-310
Overload	N/A	28-11-053	28-11-056	28-11-055	28-11-055
Contactora	N/A	28-11-057	28-11-057	21-11-057	21-11-057
Fan/Limit Thermostat	28-60-023	28-60-023	28-60-023	28-60-023	28-60-023
Fan/ limit Stat Gasket	20-33-549	20-33-549	20-33-549	20-33-549	20-33-549
Burner Plate Gasket	30-40-156	31-27-121	31-27-121	31-27-121	31-29-046
Pressure Relief Gasket	31-27-121	31-27-121	31-27-121	20-46-354	20-46-354
Sight Glass	20-30-151	20-30-151	20-30-151	20-30-151	20-30-151
Time Clock	28-15-008	28-15-008	28-15-008	28-15-008	28-15-008
Thermostat Room	28-16-031	28-16-031	28-16-031	28-16-031	28-16-031
Thermostat Frost	28-16-044	28-16-044	28-16-044	28-16-044	28-16-044
Rocker Switch Red Neon	28-40-105	28-40-105	28-40-105	28-40-105	28-40-105
Rocker Switch Dual Black	28-40-106	28-40-106	28-40-106	28-40-106	28-40-106
Rocker Switch Black	28-40-104	28-40-104	28-40-104	28-40-104	28-40-104
Fuse 1ph	28-07-049	N/A	N/A	N/A	N/A
Fuse 3ph	N/A	28-07-048	28-07-048	28-07-048	28-07-048
Motorised Fan 1ph	28-09-002	N/A	N/A	N/A	N/A
Fan	N/A	28-09-003	28-09-003	28-09-004	28-09-004
Fan Pulley	N/A	28-65-092	28-65-096	28-65-105	28-65-105
Motor	N/A	28-10-127	28-10-015	28-10-120	28-10-120
Motor Pulley	N/A	28-65-065	28-65-063	28-65-063	28-65-072
Belt	N/A	09-16-110(2)	09-16-106(2)	09-16-126(2)	09-06-126(2)
Fire Check Valve	28-30-102	28-30-102	28-30-102	28-30-102	28-30-102
Fuel Filter	29-15-017	29-15-012	29-15-012	29-15-012	29-15-012
Nozzle	27-00-032	27-00-044	27-00-078	27-00-055	27-00-032 27-00-078
Burner	29-99-453	29-99-454	29-99-455	29-99-455	29-99-554
Control	CP4	CP4	CP4	CP4	CP4

DESCRIPTION	800	1000	DESCRIPTION	1200	1300
Stackbox Assy	20-47-425	20-47-425	Gas Exit Duct Assy V	20-27-090	20-27-090
Overload	28-11-111	28-11-111	Gas Exit Duct Assy H	20-27-092	20-27-092
Contactora	28-11-057	28-11-057	Star delta starter	28-11-044	28-11-044
Fan/Limit Thermostat	28-60-023	28-60-023	Fan/Limit Thermostat	28-60-021	28-60-021
Fan/ limit Stat Gasket	20-33-549	20-33-549	Fan/ limit Stat Gasket	20-33-549	20-33-549
Burner Plate Gasket	31-29-046	31-29-046	Burner Plate Gasket	31-29-046	31-29-046
Sight Glass	20-30-151	20-30-151	Sight Glass	20-30-151	20-30-151
Fuse 3ph	28-07-048	28-07-048	Fuse 3ph	28-07-048	28-07-048
Time Clock	28-15-008	28-15-008	Time Clock	28-15-008	28-15-008
Thermostat Room	28-16-031	28-16-031	Thermostat Room	28-16-031	28-16-031
Thermostat Frost	28-16-044	28-16-044	Thermostat Frost	28-16-044	28-16-044
Rocker Switch Red Neon	28-40-105	28-40-105	Rocker Switch Red Neon	28-40-105	28-40-105
Rocker Switch Dual Black	28-40-106	28-40-106	Rocker Switch Dual Black	28-40-106	28-40-106
Rocker Switch Black	28-40-104	28-40-104	Rocker Switch Black	28-40-104	28-40-104
Fan	28-09-043	28-09-043	Fan Drive Assy (Nozzled) Fan Drive Assy (Ducted)	28-09-087 20-27-311	28-09-087 20-27-311
Fan Pulley	28-65-043	28-65-074	Driven Pulley (Nozzled) Driven Pulley (Ducted)	28-65-049 28-65-054	28-65-049 28-65-054
Fan Taper lock	28-66-136	28-66-136	Taper lock Driven (Nozzled) Taper lock Driven (Ducted)	28-66-136 28-66-019	28-66-136 28-66-019
Motor	28-65-043	28-10-021	Motor (Nozzled) Motor (Ducted)	28-10-024 28-10-025	28-10-024 28-10-025
Motor Pulley	28-65-042	28-65-181	Drive Pulley (Nozzled) Drive Pulley (Ducted)	28-65-047 28-65-053	28-65-047 28-65-053
Motor Taper lock	28-66-028	28-65-013	Taper lock Drive (Nozzled) Taper lock Drive (Ducted)	28-66-013 28-66-042	28-66-013 28-66-042
V Belt (3)	09-16-110	09-16-110	V Belt (3) Ducted V Belt (3) Nozzled	09-16-126 09-16-138	09-16-126 09-16-138
Fire Check Valve	28-30-102	28-30-102	Fire Check Valve	28-30-102	28-30-102
Fuel Filter	29-15-020	29-15-020	Fuel Filter	29-15-020	29-15-020
Top Nozzle	27-00-048	27-00-055	Top Nozzle	27-00-079	27-00-078
Bottom Nozzle	27-00-040	27-00-040	Bottom Nozzle	27-00-270	27-00-270
Burner	29-99-554	29-99-456	Burner	29-99-458	29-99-500
Control	CP4	CP4	Control	CP4	CP4

SECTION 2

BASIC USER INSTRUCTIONS

10.0 Introduction

The following information is relevant to the Oil fired Cabinet Heater range manufactured by Benson Heating. These heaters are manufactured within a strictly controlled quality system to ISO 9001.

All Benson Heating Oil Fired Cabinet Heaters are CE marked, having been found to satisfy the essential requirements of the following European Directives.

Machinery Directive (89/392/EEC)
Low Voltage Directive (73/23/EEC & 93/68/EEC)
Electromagnetic Compatibility Directive (89/336/EEC & 91/31/EEC)

Product Liability Directive (65/374/EEC)

Benson Heating support all new products being supplied to their customers with a comprehensive information pack, and it is the responsibility of the owner, user, or hirer, of such products supplied by Benson Heating to ensure that operators are provided with the operator manual, and that they are suitably instructed regarding the purpose of the manual and safety instructions. In addition to this, operators must also be suitably and adequately trained in the use of the product.

Contained within the text of this manual, the words '**Caution**' and '**Warning**' are used to highlight certain points.

Caution is used when failure to follow or implement the instruction(s) can lead to a premature failure or damage being occasioned to the heater or its component parts.

Warning is used when failure to heed or implement the instruction(s) can lead not only to component damage, but can also lead to a hazardous situation being created where there is a risk of personal injury or death

10.1 Commissioning and hand over Warning

As part of the commissioning programme, the commissioning engineer must go through the following with the operator.

- (i) Lighting, shutdown, and operational information.
- (ii) Safety features, data plate, and labelling.
- (iii) The requirement for regular inspection - especially if the heater is within a more demanding environment - and the need for regular servicing, carried out by competent and qualified engineers.

Caution

After approximately 100 hours of running, the tension on the fan belts must be checked to ensure that it is correct, and that the belts have not stretched. It is strongly advised that this is undertaken by the commissioning engineer, and not the operator.

10.2 Servicing

Warning

Servicing must be carried out on a regular basis, the maximum interval between services being one year.

It is a requirement that only suitably qualified and competent persons are allowed to undertake the servicing.

Benson Heating advise that the planned service schedule as detailed in section 5.1 of the Installation, Commissioning and Servicing Manual is adopted by the user. Further details are available from either Benson Heating or from the commissioning engineer.

10.3 Start up procedure

- (a) Ensure that the oil supply valves are open, and that the mains electrical supply is turned on
- (b) Ensure that the controller has been correctly programmed
- (c) Ensure programme is set for on setting
- (d) Ensure heat/ventilation switch to 'heat'

(e) Check for the following burner sequence

Caution

Repeated or frequent lockouts must be investigated and their cause determined by a qualified and competent engineer.

interval	o p e r a n d
-----------------	----------------------

1	<5s Combustion air damper actuated fan motor initiates purge cycle...
2	<15s Solenoid valve opens ignition transformer provides spark for burner ignition and flame detection...
3	<20s Burner ignition start cycle complete.

Note

The time intervals within the ignition sequence may vary slightly between models.

(f) The burner will continue to fire until heat is no longer demanded.

10.4 Stop procedure

(a) Set programmer to off position.

(b) The fan motor will continue to run until heat dissipation allows the fan and limit stat to shut down the fan.

Caution

Do not use the main electrical isolator to turn off the heater, to do so can cause damage to the heat exchanger and combustion chamber, and thereby invalidate the warranty.

10.5 Shut down procedure

(a) Follow steps 10.5 (a) and (b), when fan stops turn main electrical isolator off, and shut oil supply valves

10.6 Ventilation only

(a) Set heat/ventilate switch to 'ventilate'.

10.7 Lockout situations

If either the burner or the fan and limit stat go to lockout, the lockout must be cleared manually before the ignition sequence can be re-initiated.

Benson Heating
Ludlow Road
Knighton
Powys
LD7 1LP

Telephone 01547 528534

Facsimile 01547 520399

Email : information@bensonheating.co.uk

www.bensonheating.com

**Benson Heating is a Trading Name
of the Benson Group of Companies Ltd**